



HYDRAULICS

**BENCH PRESS 10 ton
WITH ELECTRIC PUMP
“ECE01113-CE”**



Abdex Hydraulics - Victoria

27 Metcalf Street,
Dandenong South, VIC. 3175

Tel: (03) 9796 3744

Email: sales@abdexhydraulics.com.au

Abdex Hydraulics - Perth

260 Allen Road,
Forrestdale, WA. 6112

Tel: (08) 9418 4988

Email: sales@abdexhydraulics.com.au

Abdex Hydraulics - Queensland

8/315 Archerfield Road
Richlands, QLD. 4077.

Tel: (03) 9796 3744

Email: sales@abdexhydraulics.com.au

INDEX

1. BEFORE USING THE EQUIPMENT2
2. TECHNICAL FEATURES3
3. ESSENTIAL SAFETY REQUIREMENTS4
 3.1 GENERAL CONSIDERATIONS.
 3.2 COMMANDS SECURITY.
 3.3 PROTECTION DEVICES AGAINST MECHANICALL RISKS.
 3.4 PROTECTION DEVICES AGAINST OTHERS RISKS.
 3.5 SECURITY IN MAINTENANCE.
 3.6 INDICATIONS.
4. TRANSPORT AND INSTALLATION.....4-5
 4.1 START UP
5. MAINTENANCE AND DAMAGES5-6
6. WARRANTY.....6
7. DECLARATION OF CONFORMITY7
ANNEX

- GENERAL DRAWING

1. BEFORE USING THE EQUIPMENT.

Before unpacking check for:

1. Oil leaks.
2. Signs of corrosion.
3. Damages in the hydraulic cylinder and the hydraulic line.
4. Damage sin the frames and accessories of the cylinder.
5. Damaged screws or connections.
6. Bad connection of the accessories.

If any anomaly it is detected, avoid the use of it and place it in a safe and far location until be repaired by an authorized service dealer.



Never use equipment suspected to be in poor conditions.

Familiarize the operators with the equipment before using it, and read and follow the instructions and recommendations included in the packaging.

Any improper use, do not observed in this manual, and the omission of the same, may cause personal injuries and material damages which LARZEP, S.A. will not be responsible.



Do not loose the instruction manual.

Do not work with the equipment near of the flames, explosives, warm intense sources, or any other source which may produce fire, or which may produce damages in the equipment. The hydraulic equipment must not be exposed to temperatures greatest than 60°C, as on use as on storage.



If you are purchasing a cylinder or pump, for the use of it in the press, make sure that you are using a correct combination before assembling it. We recommended, asking for advice in this questions to our technicians.

When a place to the press is located, make sure that there is in a stable surface, is to say, that all base of the press, be supported. If any doubts exist about this question, it is recommended that distribute the weight in a bigger area, placing a steel shell behind the press’s base.

Store the press when the piston is fully retracted. It is recommended protecting the cylinder with a plastic, or place the press in a clean area, for not damaging the components and for keeping the press correctly storage.



Never locate the press or store in a place where the children could access to it.

2. TECHNICAL FEATURES.

HYDRAULIC CYLINDER

MODEL	KC01113
• Push capacity (ton)	10 ton
• Maximum pressure (Kg/cm ²)	700 Kg/cm ²
• Stroke (mm)	130 mm
• Effective area (cm ²)	15.9 cm ²
• Oil capacity (cm ³)	214.7 cm ³
• Approach speed (mm/sg)	31 mm/sg
• Working advance speed (mm/sg)	5.8 mm/sg

HYDRAULIC MOTORPUMP. REF: HAM7224B

MODEL	HAM7224B
• Tank capacity	5 Litros útiles.
• Volume in low pressure. Approaching	4 Litros/min
• Volume in high pressure. Working.	0.36 Litros /min
• Maximum pressure.	700 Kg/cm ²
• Control valve	Manual Aluminio: 3 vías, 3 posiciones.
• Motor	0, 75 kW Tensión: 400V. 50Hz.3ph.

FRAME: MECHANICAL-WELDED

MODEL	ECE01113-CE
• Working height (mm)	352 mm
• Working width (mm)	350 mm
• Weight (Kg)	75 Kg

DESCRIPTION POWERPACK HAM7224B (See the figure).

The motor pump has the following part:

- Metal tank with oil level.
- Metal lid, support for the entire hydraulic circuit.
- Electric motor with corresponding coupling.
- Hydraulic piston pump with filter.
- Transportation plug and ventilation plug (plastic bag).
- Pressure meter connection.
- Motor circuit breaker box.
- Manual distributing valve with 3/8 NPT outputs.
- Internal safety valve adjusted to 700 bar.
- Adjustable external pressure regulating valve: 0-700 bar.



3. ESSENTIAL SAFETY REQUIREMENTS.

3.1 GENERAL CONSIDERATIONS

DANGEROUS AREA



Due to the *FUNCTIONAL REASONS* it is considered to be the space between the columns, the bed and the hydraulic cylinder piston.
Due to the *MATERIAL PRESSED* it is supposed to be surrounding area to the machine in case of metal parts being ejected during pressing.

The speed of the hydraulic cylinder during its extension is less than 30 mm/second. Therefore then machine should be considered by the application of ANNEX V of the Declaration of CE Conformity.

Operators standing in the dangerous area around the machine should protect their feet, faces and hands from metal pieces being ejected during pressing.



Feet protection



Face protection



Hands protection

Used materials and components are not dangerous for the health and safety of operators. The hand pump contains LARZEP hydraulic oil ISO: HV46.



HIDRAULIC OIL IS TOXIC IF IT ENTERS THE BLOODS STREAM. NEVER PLACE A FINGER OVER ANY ORIFICE OR LEAK, WHICH COULD BE PRESSURIZED, SUCH AS THE HYDRAULIC LINE, AS THIS COULD CAUSE OIL TO BE INJECTED INTO BLOOD STREAM.

3.2 COMANDS

The cylinder advances when we act over the powerpack, push the general swicht (1-0) of the electrical cabinet or circuit motor breaker box.

To stop the motor we must push the red button.

We have to check the sense of the motor turn, it must be the same as the narrow labelled in the motor protector, if it does not coincide swap two cables between in the terminal.

The hose connection is made; if not, the manual distributor valve have two outlets for the connection. The outlet labelled with "A" is the one to connect, the other outlet labelled with "X" must be corking.

The operating of the distributor valve: If we act over the valve and we put it in "A" position, the cylinder will advance. When we put the valve in "T" position, the cylinder will return and finally when the valve is in "C" position the pressure will be maintained.

3.3 SAFETY PREVENTIVE ACTIONS AGAINST MECHANICAL RISKS

The construction of machine has been calculated to bear without any breaking under conditions of foreseen utilization and for the whole life of the machine. The hydraulic components have been designed and calculated in compliance with the ANSI B30.1, and have been proved to 875Kg/cm² of pressing. The frame of the machine does not cause to be dangerous in that sense.

3.4 SAFETY PREVENTIVE ACTIONS AGAINST OTHER RISKS.

The machine is provided with a thermal relay to protect the motor.

The hydraulic pump is equipped with an internal security valve in the tank, out of operator's control and rated at 700 Kg/cm². The hydraulic cylinder is also furnished with a pressure relief valve, rated at 700 Kg/cm², which could be rated by the operator from 0 to 700 Kg/cm².

3.4 MAINTENANCE

All the maintenance operations must be performed while the machine is stopped, thus avoiding this way any potentially dangerous situation. A poor maintenance program of the press does not increase the risk, but obviously will revert in a lower performance.

The hydraulic pump is mounted out of the frame and access is very easy. To disassemble the pump unscrews the bolts in the tap cover. In order to disassemble the cylinder it is required first to disassemble the piping and the cylinder from the frame.

ISOLATION OF POWER SUPPLY

Release the cables of the terminal to disconnect the current tap of electrical energy, previously disconnect the pin from the network.

3.6 INDICATIONS

INFORMATION DEVICES

- In the pump: Oil level, oil filling tap, pressure relief valve, additional gauge port.
- In the cylinder: A gauge in order to know the operating pressure anytime.

The press, the cylinder and the pump have their corresponding serial numbers marked on them. In addition to it, you can find a sticker label showing the commercial reference, capacity, working pressure, name and address of the manufacturer.

4. TRANSPORT AND INSTALLATION.

The machine is delivered properly packed in a wooden pallet. For its handling, it is recommended to use a forklift truck or a crane. In the last case, it is necessary to make the slings trespass the arc of the frame. When doing this operation, you should be cautious and prevent the flexible hoses and couplings from any damage.



The machine is stable enough to operate without fixing, but if is placed in an area commonly operated by mobile machinery (cranes, lifting equipment...) it is strongly recommended to fix it to the desired place by drilling the supporting plates.

HYDRAULIC CONNECTION

Unscrew the rapid coupler site in the cylinder, and connect the hose, screwing the rapid coupler to the limit with the hand.

SUBSTITUTION OF THE TRANSPORT PLUG

Replace the plug of the transport located in the cover of the tank by the pressurized plug given with the press. (Plastic stock marked in the handle of the distributing valve).

INSTALLING THE GAUGE

- 1-Replace the threaded tap in the top of the cylinder by the gauge, which is supplied separately.
- 2-Tighten the gauge cone to the gauge adaptor seat by using a flan wrench size 22.
- 3-Hold the gauge screen by hand during threading process and after reaching a comfortable reading position set the gauge screen free so that it turns the last quarter solidarily with the thread.
- 4- The power pack is also provided with a gauge adaptor, with thread 3/8" BSP.

ELECTRIC CONNECTION

- 1- Connect the binding post to the network
- 2- See the voltage, it must be 380 V
- 3- Assure that the valve is in neutral position; it is to say "C" position.
- 4- Put the general selector in (1) position. The motor starts.
- 5- Check that the motor goes in the sense labelled with an arrow in the motor. In opposite case, change the position of two cables between themselves in the terminal and try again. This operation must be done with the equipment disconnected.
- 6- Connect again the equipment and check the function.

CHECKING THE RIGHT OPERATION OF ALL DEVICES AND MECHANISM

1. Select the working maximum pressure.
2. Start the motor.
3. Check that the cylinder's piston advance.
4. Check that the cylinder's piston returns pushing by an internal spring. In both cases act over the valve as explained in previous point.
5. With no material in the press, repeat the movement of advance, reaching the end of the stroke of the cylinder. In this moment the pressure will go increasing, so the gauge will read the pressure. This pressure will go increasing until reach the maximum pressure of the installation, previously chosen. The cylinder maintains the reached pressure and the gauge the pressure reading.
6. Check that there are not oil leaks.
7. Act over the valve and return the piston. It returns by the internal spring. The return could be slower in the end of the return stroke.
8. Put the material to be treated in the press.
9. Once the operation is finished, push the red button to stop the motor.
10. Put the general selector in (0) position,

Instruction Manual
Bench Press with Electric Pump “ECE01113-CE”

4.1 START UP

Connect the machine as described in the previous point.
 The maximum pressure that the hydraulic equipment develops is 700 Kg/cm².
 The machine is provided with an external limiter valve rated on factory at 700 Kg/cm².
 In the cover of the power pack is located the pressure regulation screw.
 Release the lock nut and go tightening or releasing the screw, go checking with the gauge, and once that the wished pressure is reached; tighten the lock nut to avoid that the vibration may decontrol the system.

5. MAINTENANCE.

The hydraulic circuit of the press is closed, so in normal conditions no oil leakage should be coming up.
 In case of oil leakage, after the proper repairing work, you should fill up the tank with hydraulic oil by LARZEP (Ref. AZ8901); the pump is equipped with an oil level indicator to control the need quantity of oil.

As far as a non-continuous use of the press is concerned (1 hour per day), oil replacement should be done once a year.
 To empty the tank, you should remove the cover and take the oil out to another container. Please, bear in mind the existing rules for waste processing when handling the used oil.

Keep greasy and lubricated the pin bearings, the piston and in general all the parts that might be in friction.
USE ONLY LARZEP HYDRAULIC OIL

Other grades of oils or types of hydraulic fluid (such as brake fluid) may affect the performance of the equipment or cause the deterioration of the seals.



DO NO ATTEMPT TO FILL THE PUMP WITH OIL WHILE IT IS CONNECTED TO A CYLINDER WHICH IS SUSTAINING A LOAD BECAUSE IT MAY OVERPRESSURIZE THE RESERVOIR WHEN THE PISTON RETRACTS AND CAUSE DAMAGE OR INJURY

Always use the original LARZEP parts to prolong the service life of your hydraulic equipment. LARZEP S.A. or your authorized dealer can supply you with original parts for simple maintenance work.

PROBLEMS	POSSIBLE FAILLURES	SOLUTION
1. The piston does not advance.	- Primeless pump.	1. Feed the pump keeping it started some minutes.
	- Dirty accumulated in the filter.	2. Extract and clean it.
	-No oil in the reservoir.	3. Check the level.
	- Cylinder pressure retainer damaged.	4. Replace the retainer.
	-Directional valve damaged.	5. Replace the valve.
	- Cylinders body damaged.	6. Repair the body of the cylinder.
2. The cylinder does not reach pressures.	- Pneumatic problem.	7. Check the installation.
	- Pressure relief valve unrated.	8. Rate the valve.
	- Cylinder pressure retainer damaged.	See Solution. 4.
3. The cylinder does not maintain pressure.	- Cylinders body damaged.	See Solution. 6.
	- Cylinder pressure retainer damaged.	See Solution. 4.
4. The cylinder does not retract.	- Directional valve damaged.	See Solution. 5.
	- Damaged return spring.	9. Replace the spring.
	- Directional valve damaged.	See Solution. 5.

*The solutions marked in black must be carried out by specialized personnel, for it, go to an authorized distributor that sold you the equipment or to LARZEP, S.A., we have original spare part kits as well as the necessary personnel, do not doubt in contacting to us, we are to yours disposition.
 Always use original spare parts LARZEP, you will extend the life utility of the equipment, in opposite case the company will not become person in charge of the possible failures, damages or losses that take place.*

6. WARRANTY.

LARZEP, S.A. guarantees its products against all design and manufacturing defects for the durations of two years from the date of purchase. This guarantee does not include the ordinary wear of both metal and non-metal parts, abuse, using the equipment beyond its rated capacity and any wear or damage incurred as a result of using a hydraulic fluid which is not recommended by LARZEP, S.A.
 Please note that if the equipment is disassembled or serviced by anyone other than an authorized service dealer or by LARZEP, S.A., this guarantee is rendered null and void.

In the event of a warranty claim, return the equipment, to LARZEP, S.A. or the authorized dealer which sold you the hydraulic equipment, LARZEP, S.A. will repair or replace the faulty equipment, whichever is deemed most appropriate. LARZEP, S.A. shall not be held liable for any consequential damages or losses, which may occur as a result of faulty equipment

7. DECLARATION OF CONFORMITY.

DECLARACION DE CONFORMIDAD

LARZEP, S.A.
Dirección: Avda. Urtiaga, 6
48269 Mallabia ESPAÑA

Declaramos bajo nuestra exclusiva responsabilidad la conformidad de los productos a los que refiere esta declaración, con las disposiciones de la directiva: 89/392/CEE, 91/368/CEE, 93/44/CEE, 93/68/CEE, 98/37/CEE

E

DECLARATION DE CONFORMITE

Nous, LARZEP, S.A.
Adresse: Avda. Urtiaga, 6
48269 Mallabia SPAIN

Déclarons sous notre seule responsabilité que les produits auxquels se réfère cette déclaration sont conformes aux dispositions des Directives: 89/392/EEC, 91/368/EEC, 93/44/EEC, 93/68/EEC, 98/37/EEC

F

DECLARAÇÃO DE CONFORMIDADE

Nós, LARZEP, S.A.
Endereço: Avda. Urtiaga, 6
48269 Mallabia SPAIN

Declaramos, sob nossa única responsabilidade, que os seguintes produtos, incluídos nesta declaração estão em conformidade com o disposto na Directiva: 89/392/EEC, 91/368/EEC, 93/44/EEC, 93/68/EEC, 98/37/EEC

P

ÖVERENSSTEMMELSESERKLÄRING

Vi, LARZEP, S.A.
Adresse: Avda. Urtiaga, 6
48269 Mallabia SPAIN

Erklærer på eget ansvar, at følgende produkter som er omfattet af denne erklæringen, er i overensstemmelse med bestemmelsene i Direktiv: 89/392/EEC, 91/368/EEC, 93/44/EEC, 93/68/EEC, 98/37/EEC

DK

ERKLÆRINGOM OVERENSSTEMMELSE

Vi, LARZEP, S.A.
Adresse: Avda. Urtiaga, 6
48269 Mallabia SPAIN

Erklærer på eget ansvar, at følgende produkter som dekkes af denne erklæringen, er i overensstemmelse med bestemmelsene i Direktiv: 89/392/EEC, 91/368/EEC, 93/44/EEC, 93/68/EEC, 98/37/EEC

N

ÜBEREINSTIMMUNGSERKLÄRUNG

Wir, LARZEP, S.A.
Anschrift: Avda. Urtiaga, 6
48269 Mallabia SPAIN

Erklären auf eigene Verantwortung, daß folgende Produkte, auf die sich diese Erklärung bezieht, mit den Bedingungen der Direktiven 89/392/EEC, 91/368/EEC, 93/44/EEC, 93/68/EEC, 98/37/EEC übereinstimmen.

D

Tipo, Type, Typ, Tyypä.

**SM / SH / SP / SMP / SX / SMX / ST / STX / SL / SMA / SHA / SSR / T / TE / TD / D / DH /
DDR / Z / ZR / W / X / YA / YG / YZ / HM / HE / HG / HZ / HS / WI / CK / CC / CN / FU / FV
/ FZ / FA / CY / AA / AU / CT / C / KC**

**A / AB / AC / BL / B / AF / F / HN / DLG / DL / DP / VA / VB / VC / VZ / EC / EE / EG / EM /
EZ / CA / CS**

Mallabia, ESPAÑA 2005 / 04 / 27

Lugar y fecha, place and date, lieu et date, plats och datum, paikka ja päivämäärä, udstedelsessted og dato, ort und datum, plaats en datum, local e data, luogo e data.

DECLARATION OF CONFORMITY

We, LARZEP, S.A.
Address: Avda. Urtiaga, 6
48269 Mallabia SPAIN

Declare under our sole responsibility that the following products to which this declaration relates conform with the provisions of Directives: 89/392/EEC, 91/368/EEC, 93/44/EEC, 93/68/EEC, 98/37/EEC

GB

DICHIARAZIONE DI CONFORMITÀ

Noi, LARZEP, S.A.
Indirizzo: Avda. Urtiaga, 6
48269 Mallabia SPAIN

Dichiariamo sotto la nostra esclusiva responsabilità che i prodotti ai quali questa dichiarazione si riferisce sono conformi quanto previsto dalle Direttive: 89/392/EEC, 91/368/EEC, 93/44/EEC, 93/68/EEC, 98/37/EEC

I

VAATIMUSTEMUKAISUUSVAKUUTUS.

Me, LARZEP, S.A.
Osoite: Avda. Urtiaga, 6
48269 Mallabia SPAIN

Vakuutamme yksinomaan omalla vastuullamme, että seuraavat tuotteet, joihin tämä vakuutus liittyy, ovat seuraavien Direktiivien vaatimusten mukaisia: 89/392/EEC, 91/368/EEC, 93/44/EEC, 93/68/EEC, 98/37/EEC

FIN

VERKLARINGVAN OVEREENKOMST.

Wij, LARZEP, S.A.
Adres: Avda. Urtiaga, 6
48269 Mallabia SPAIN

Verklaren geheel onder eigen verantwoordelijkheid dat de volgende producten, waarop deze verklaring heeft in overeenstemming zijn met de bepalingen van Richtlijn: 89/392/EEC, 91/368/EEC, 93/44/EEC, 93/68/EEC, 98/37/EEC

NL

FÖRSÄKRAN OM ÖVERESSTÄMMELSE

Vi, LARZEP, S.A.
Adress: Avda. Urtiaga, 6
48269 Mallabia SPAIN

Försäkrar under eget ansvar att följande produkter som omfattas av denna försäkran är i överensstämmelse med villkoren i Direktiv: 89/392/EEC, 91/368/EEC, 93/44/EEC, 93/68/EEC, 98/37/EEC

S

LARZEP, S.A.

Nombre y firma, name and signature, nom et signature, namn och underskrift, nimi ja nimikirjoitus, navn og underskrift, name und underskrift, naam en handtekening, nome e assinatura, nome e firma.

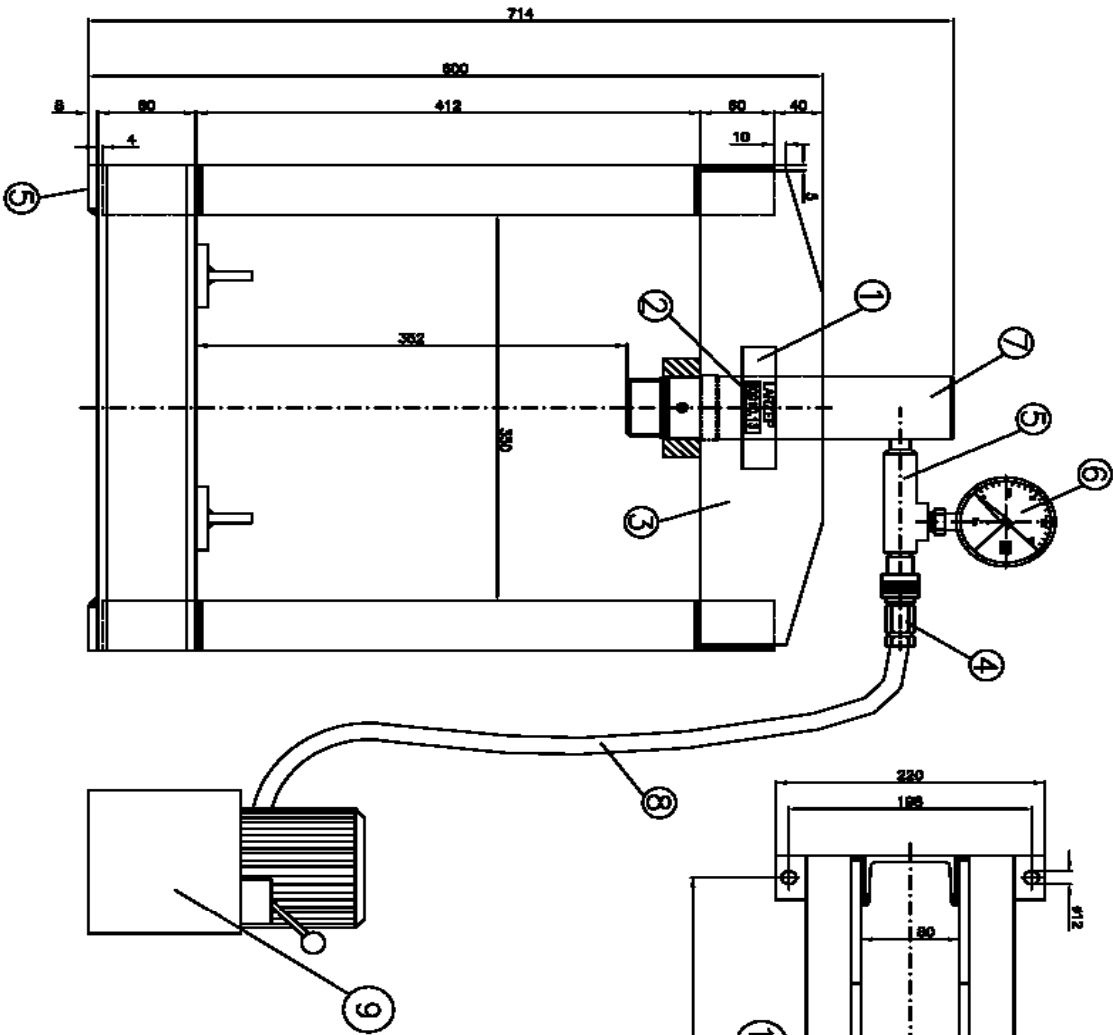

PRENSA HIDRAULICA DE COLUMNA

CODIGO: ECE01113

DATOS DE LA PRENSA:

CAPACIDAD 10 Tm

LUZ ENTRE COLUMNAS 350 mm

N	DENOMINACION	CODIGO	N
1	ETIQUETA ADHESIVA	30A0021	1
2	ETIQUETA ADHESIVA	30A0050	1
3	ESTRUCTURA	25A0017	1
4	ENCHUFE RAPIDO MACHO	AZ3220	1
5	ADAPTADOR MANOMETRO	AZ1501	1
6	MANOMETRO	AV01008	1
7	CILINDRO	KC01113	1
8	MANGUERA	AP2015	1
9	ELECTRO-BOMBA	YAM6224	1
10	PROTECTOR ROSCA	15L0018	1
11	ESPARRAGO	14F0010	1
12	TAPON MANOMETRO	15L0014	1

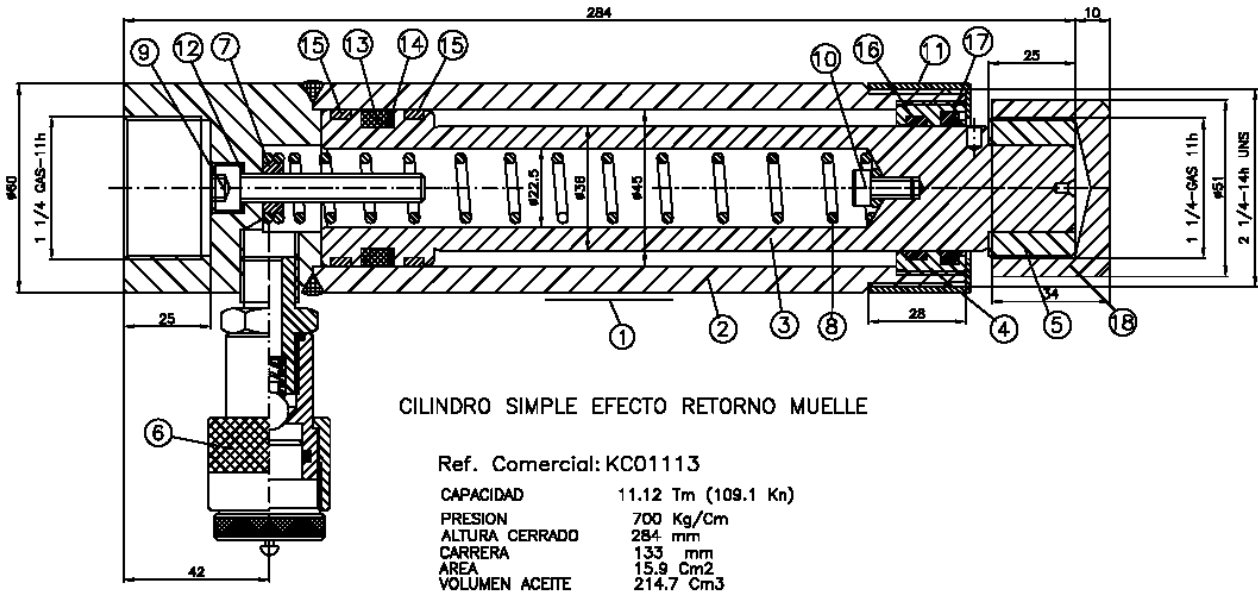

N	DENOMINACION	REFERENCIA JUNTAS	CODIGO	N Piezas
1	ETIQUETA		30A0017	1
2	C.CUERPO		52H0007	1
3	EMBOLO		53H0012	1
4	GUIA		55E0054	1
5	CABEZA		56H0008	1
6	ENCHUFE HEMBRA P.C		AZ3240	1
7	AMARRA MUELLE		24F0071	1
8	MUELLE		13A0139	1
9	TORNILLO ALLEN M8x55 TODO ROSCA		14A0117	1
10	TORNILLO ALLEN M6x10		14A0004	1
11	PROTECTOR ROSCA		12L0002	1
12	ARANDELA COBRE		57B0005	1
* 13	COLLARIN $\phi 45 \times \phi 35 \times 7.3$	4315700	12B0199	1
* 14	SEGMENTO		57A0052	1
* 15	ARO GUIA $\phi 45 \times 40 \times 5.6$	GP6500450-C380	58F0136	2
* 16	ARO GUIA $\phi 36 \times 41 \times 5.6$	GR6500360-C380	58F0123	1
* 17	RASCADOR $\phi 36 \times \phi 44 \times 6$	WD2200360-WUAQ3	12H0063	1
18	CABEZA DENTADA		56H0003	1

* JUEGO DE RECAMBIOS