



HYDRAULICS

HYDROPNEUMATIC TROLLEY 2-PISTON 15/30 “HN-231”



Abdex Hydraulics - Victoria
27 Metcalf Street,
Dandenong South, VIC. 3175
Tel: (03) 9796 3744
Email: sales@abdexhydraulics.com.au

Abdex Hydraulics - Perth
260 Allen Road,
Forrestdale, WA. 6112
Tel: (08) 9418 4988
Email: sales@abdexhydraulics.com.au

Abdex Hydraulics - Queensland
8/315 Archerfield Road
Richlands, QLD. 4077.
Tel: (03) 9796 3744
Email: sales@abdexhydraulics.com.au

INDEX

1. BEFORE USING THE EQUIPMENT ----- 2
2. ESSENTIAL SAFETY REQUIREMENTS ----- 2
3. TECHNICAL FEATURES ----- 2-3

- START UP
- ENVIROMENTAL CONDITIONS

4. START UP ----- 3
5. MAINTENANCE ----- 3
6. WARRANTY ----- 3
7. DECLARATION OF CONFORMITY ----- 4

1. BEFORE USING THE EQUIPMENT.

Before using the hydraulic Trolley, read carefully these instructions and familiarize with security pictures.

This manual is a part of the machine is obligatory to read it and must be conserved.

The symbols used in this manual are the following:

 **ATTENTION:** This symbol depicts a security advertence, and looks that we have following strictly the manual indications. If we do not do it, should produce material damages or personal injuries, also lethal damages.

 Put the load settled.

 Block the load and do not operate behind this.

The omission of these instructions may cause material and personal injuries that LARZEP, S.A. will not be responsible.

On the unpacking moment check that the hydro pneumatic Trolley is not damaged, or it have loosen pieces.

If any anomaly, damage, sign of corrosion, or any fault is find, do not use the equipment, store it in a clean place and where the children can not access it, until the equipment be repaired or substituted.

 **Never use faulty equipment.**

The hydropneumatic Trolley has been designed and fabricated in order to elevate vehicles, the principal groups are:

- 1- Pump and engine group.
- 2- Cylinder-tank group.
- 3- Hydraulic block group.
- 4- Depressor group.
- 5- Lever group.
- 6- Chassis-housing group.

2. ESSENTIAL SAFETY REQUIREMENTS.

- Do not operate the overpressure valve, which is strapped.
- Before start the elevate operation, block the vehicle placing wedges in accordance with the wheels.
- Put the load in a way that stay settled in the cylinder's piston plate.

 • Settled load.

- Once the load is elevated, is necessary to block it, in order to avoid risks.

 • Block the load and do not operate behind it.

- Do not elevate the load in restricted areas in order to avoid the risk of been trapped.
- During the elevating and descending operations it must be assure that there is nobody under the load.
- Do not elevate load in irregular surfaces, or dipped surfaces, to avoid the risk of dumping.
- Do not assemble extensions or use spare parts that there is not authorized by your dealer or LARZEP, S.A.
- There is the possibility to connect supplies to the piston of 70 mm and 120 mm.

3. TECHNICAL FEATURES.

MODEL	HN-231
MAXIMUM CAPACITY	30 / 15 ton
HEIGHT	150 mm.
TOTAL STROKE OF PISTONS	150 mm.
FEED MAXIMUM PRESSURE	8,5 / 12
DIMENSIONS	520x300x1315
WEIGHT	39 Kg.

START UP

The hydro pneumatic trolley is properly packed in a wooden pallet.

In order to start up, unpack the equipment and read the instruction manual.

The manual must be accessible to the operators, familiarize with the equipment and your co-workers, do not loose it.

- 1- Release the lever (5) and the cylinder (2).
- 2- Introduce the lever in the hole provided to it, located in the chassis (6), and put the fastening socket with the pin, checking that there are tighten, using if is necessary any drop of auto blocking.
- 3- Connect the two tubes of air, between the lever and the chassis using the connections provided in the lever in accordance with the tubes which have the same colour.

Connection with the installation of compressed air.

The compressed air goes into the circuit by means of the rapid coupler located in the superior right side of the lever; is necessary to have a connection tube with a rapid coupler compatible with the Hydro pneumatic Trolley's junction.

Check with a gauge the maximum pressure of working that never must be higher than 12 Bar.

The machine is provided with two extensions and a plate with circular dents (120 mm y 70 mm)

Never introduce in the compressed air circuit, hydraulic oil, Vaseline oil, break liquid, petrol or other liquids.

Cut in the installation of air with a dehumidification machine.

If you wish lubricate the circuit, use only:

AGIP OSO 100, MOBIL DTE 27, ESSO TERESSO 100, SHELL TELLUS 100, BP ENERGOL HP 100.

ENVIROMENTAL CONDITIONS

The hydropneumatic Trolley runs in normal environmental conditions, being the minimum and maximum temperatures that supported respectively: -20°C and +50°C.

4. START UP.

- 1- Enforce the security rules of this manual.
- 2- Support the Hydro pneumatic Trolley in a stable and safety surface.
- 3- To elevate the load, turn to the right (respect the operator) the command (5).
- 4- Block the load once is elevated.
- 5- To descend the load, turn the command (5) to the left (respect the operator's position)
- 6- The chief of the operator must be responsible of provide to the personnel, the needed information and the necessary training about the pumping and translation forces.
- 7- In case of distributor's break during the use, close the security faucet, located in the command (5) between the rapid coupler of air connection, and the proper distributor.

IMPROPER USE



This Jack has been designed and engineered in order to elevate means of transport, any other use of the jack like persons elevation or displacement, is considered improper, as well as any other use do not contemplate in this manual, and which do not respect the security rules.

5. MAINTENANCE.

The jack is provided with a lever with 3 positions and with a distributor valve 4/3 mono-stable.

In case of break or disconnection of the air tube, the jack blocks immediately.

To make longer the life of the jack, is recommended to clean the pistons externally fortnightly.

Check two a year unless, the oil level in the tank, this control must being done with the pistons fully retracted. It is necessary to check the oil level unscrewing the pin.

- In case of being necessary refill the tank with oil, check that you are using recommended oil, and compatible, in opposite case the equipment could result damaged.

- If the oil level is higher than anticipate, or the jack has been dumped, the oil is expelled by means of depressor in way of fog.

This phenomenon disappears itself when the oil level is the correct, if the level is very higher is recommended to retract it until reaching the correct level, and follow the rules of residues treatment.

- If the motor starts but the load do not elevate, check the oil level, if is a lack, add oil and purge the circuit.

To do this operation, with the piston fully extended, put the jack in vertical position and close the faucet, continue placing the command in descend position until the piston retracts fully and when is only the oil which goes out, check again the oil level and open the faucet.

Any other fault or damage, consult with your authorized service dealer or with LARZEP, S.A., those are provided of specialist personnel necessary in order to do other kinds of maintenance operation and the necessary repairs. Do no doubt in consult us; we are to your disposition.

6. WARRANTY.

LARZEP, S.A. guarantees its products against all design and manufacturing defects for the durations of two years from the date of purchase. This guarantee does not include the ordinary wear of both metal and non-metal parts, abuse, using the equipment beyond its rated capacity and any wear or damage incurred as a result of using a hydraulic fluid which is not recommended by **LARZEP, S.A.**

Please note that if the equipment is disassembled or serviced by anyone other than an authorized service dealer or by **LARZEP, S.A.**, this guarantee is rendered null and void.

In the event of a warranty claim, return the equipment, to **LARZEP, S.A.** or the authorized dealer which sold you the hydraulic equipment, **LARZEP, S.A.** will repair or replace the faulty equipment, whichever is deemed most appropriate. **LARZEP, S.A.** shall not be held liable for any consequential damages or losses, which may occur as a result of faulty equipment

7. DECLARATION OF CONFORMITY.

DECLARACION DE CONFORMIDAD

LARZEP, S.A.
Dirección: Avda. Urtiaga, 6
48269 Mallabia ESPAÑA

Declaramos bajo nuestra exclusiva responsabilidad la conformidad de los productos a los que refiere esta declaración, con las disposiciones de la directiva:
89/392/CEE, 91/368/CEE, 93/44/CEE, 93/68/CEE, 98/37/CEE

E

DECLARATION OF CONFORMITE

Nous, LARZEP, S.A.
Adresse: Avda. Urtiaga, 6
48269 Mallabia SPAIN

Déclarons sous notre seule responsabilité que les produits auxquels se réfère cette déclaration sont conformes aux dispositions des Directives:
89/392/EEC, 91/368/EEC, 93/44/EEC, 93/68/EEC, 98/37/EEC

F

DECLARAÇÃO DE CONFORMIDADE

Nós, LARZEP, S.A.
Endereço: Avda. Urtiaga, 6
48269 Mallabia SPAIN

Declaramos, sob nossa única responsabilidade, que os seguintes produtos, incluídos nesta declaração estão em conformidade com o disposto na Directiva:
89/392/EEC, 91/368/EEC, 93/44/EEC, 93/68/EEC, 98/37/EEC

P

ÖVERENSSTEMMELSEERKLÆRING

Vi, LARZEP, S.A.
Adresse: Avda. Urtiaga, 6
48269 Mallabia SPAIN

Erklærer på eget ansvar, at følgende produkter som er omfattet af denne erklæringen, er i overensstemmelse med bestemmelserne i Direktiv:
89/392/EEC, 91/368/EEC, 93/44/EEC, 93/68/EEC, 98/37/EEC

DK

ERKLÆRING OM ÖVERENSSTEMMELSE

Vi, LARZEP, S.A.
Adresse: Avda. Urtiaga, 6
48269 Mallabia SPAIN

Erklærer på eget ansvar, at følgende produkter som dekkes av denne erklæringen, er i overensstemmelse med bestemmelserne i Direktiv:
89/392/EEC, 91/368/EEC, 93/44/EEC, 93/68/EEC, 98/37/EEC

N

ÜBEREINSTIMMUNG-SERKLÄRUNG

Wir, LARZEP, S.A.
Anschrift: Avda. Urtiaga, 6
48269 Mallabia SPAIN

Erklären auf eigene Verantwortung, daß folgende Produkte, auf die sich diese Erklärung bezieht, mit den Bedingungen der Direktiven 89/392/EEC, 91/368/EEC, 93/44/EEC, 93/68/EEC, 98/37/EEC übereinstimmen.

D

Tipo, Type, Typ, Tyypki.

**SM / SH / SP / SMP / SX / SMX / ST / STX / SL / SMA / SHA / SSR / T / TE / TD / D / DH /
DDR / Z / ZR / W / X / YA / YG / YZ / HM / HE / HG / HZ / HS / WI / CK / CC / CN / FU / FV
/ FZ / FA / CY / AA / AU / CT / C / KC**

**A / AB / AC / BL / B / AF / F / HN / DLG / DL / DP / VA / VB / VC / VZ / EC / EE / EG / EM /
EZ / CA / CS**

Mallabia, ESPAÑA 2005 / 04 / 27

Lugar y fecha, place and date, lieu et date, plats och datum, paikka ja päivämäärä, udstedelsessted og-dato, ort und datum, plaats en datum, local e data, luogo e data.

DECLARATION OF CONFORMITY

We, LARZEP, S.A.
Address: Avda. Urtiaga, 6
48269 Mallabia SPAIN

Declare under our sole responsibility that the following products to which this declaration relates conform with the provisions of Directives:
89/392/EEC, 91/368/EEC, 93/44/EEC, 93/68/EEC, 98/37/EEC

GB

DICHIARAZIONE DI CONFORMITÀ

Noi, LARZEP, S.A.
Indirizzo: Avda. Urtiaga, 6
48269 Mallabia SPAIN

Dichiariamo sotto la nostra esclusiva responsabilità che i prodotti ai quali questa dichiarazione si riferisce sono conformi quanto previsto dalle Direttive:
89/392/EEC, 91/368/EEC, 93/44/EEC, 93/68/EEC, 98/37/EEC

I

VAATIMUSTEMUKAISUUSVAKUUTUS.

Me, LARZEP, S.A.
Osoite: Avda. Urtiaga, 6
48269 Mallabia SPAIN

Vakuutamme yksinomaan omalla vastuullamme, että seuraavat tuotteet, joihin tämä vakuutus liittyy, ovat seuraavien Direktiivien vaatimusten mukaisia:
89/392/EEC, 91/368/EEC, 93/44/EEC, 93/68/EEC, 98/37/EEC

FIN

VERKLARING VAN OVEREENKOMST.

Wij, LARZEP, S.A.
Adres: Avda. Urtiaga, 6
48269 Mallabia SPAIN

Verklaren geheel onder eigen verantwoordelijkheid dat de volgende producten, waarop deze verklaring heeft in overeenstemming zijn met de bepalingen van Richtlijn:
89/392/EEC, 91/368/EEC, 93/44/EEC, 93/68/EEC, 98/37/EEC

NL

FÖRSÄKRAN OM ÖVERESSTÄMMELSE

Vi, LARZEP, S.A.
Adress: Avda. Urtiaga, 6
48269 Mallabia SPAIN

Försäkrar under eget ansvar att följande produkter som omfattas av denna försäkran är i överensstämmelse med villkoren i Direktiv:
89/392/EEC, 91/368/EEC, 93/44/EEC, 93/68/EEC, 98/37/EEC

S

LARZEP, S.A.

Nombre y firma, name and signature, nom et signature, namn och underskrift, nimi ja nimikirjoitus, navn og underskrift, name und underskrift, naam en handtekening, nome e assinatura, nome e firma.

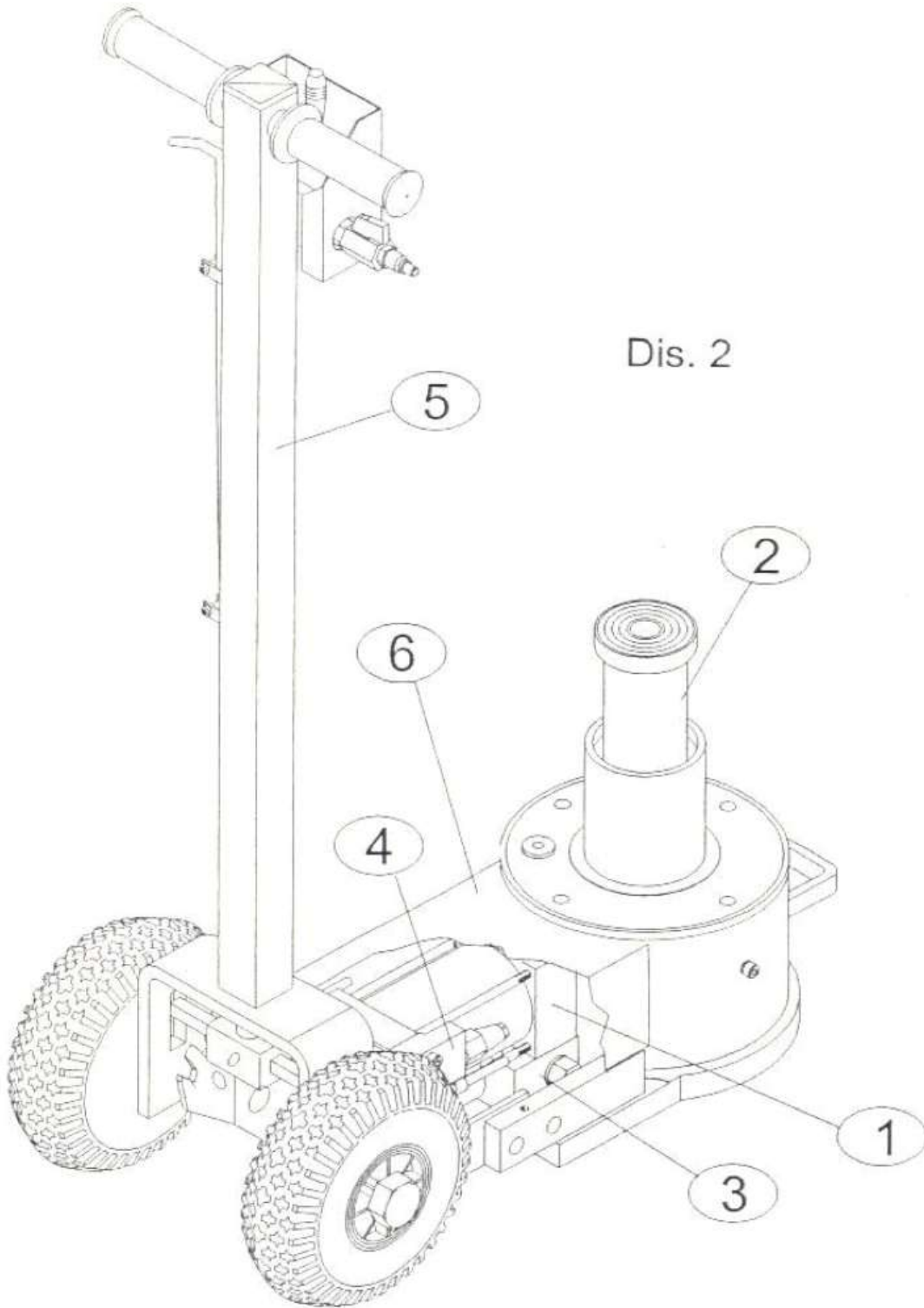

Instruction Manual
Hydropneumatic Trolley 2-Piston "HN-231"

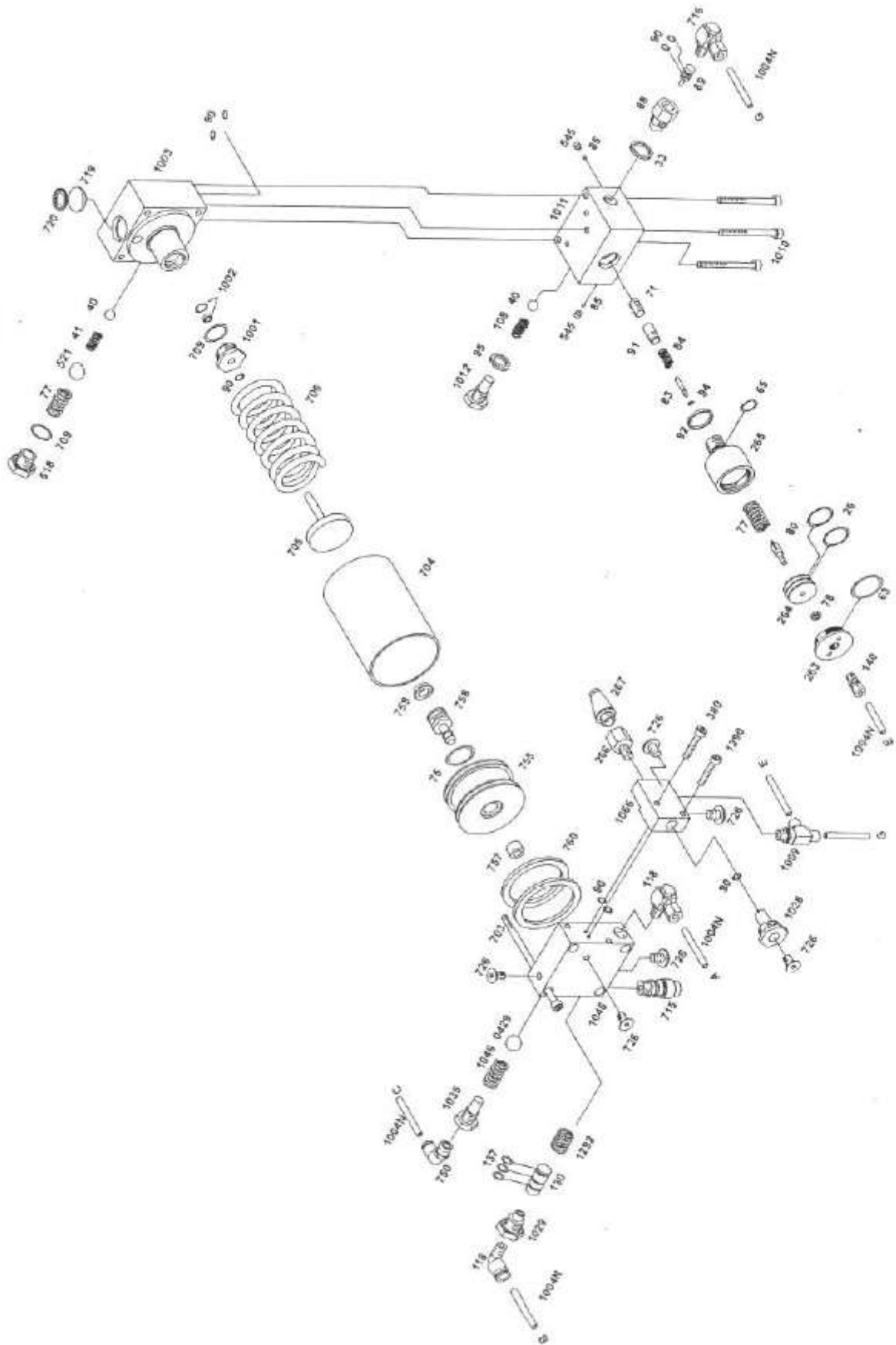

Instruction Manual
Hydropneumatic Trolley 2-Piston “HN-231”

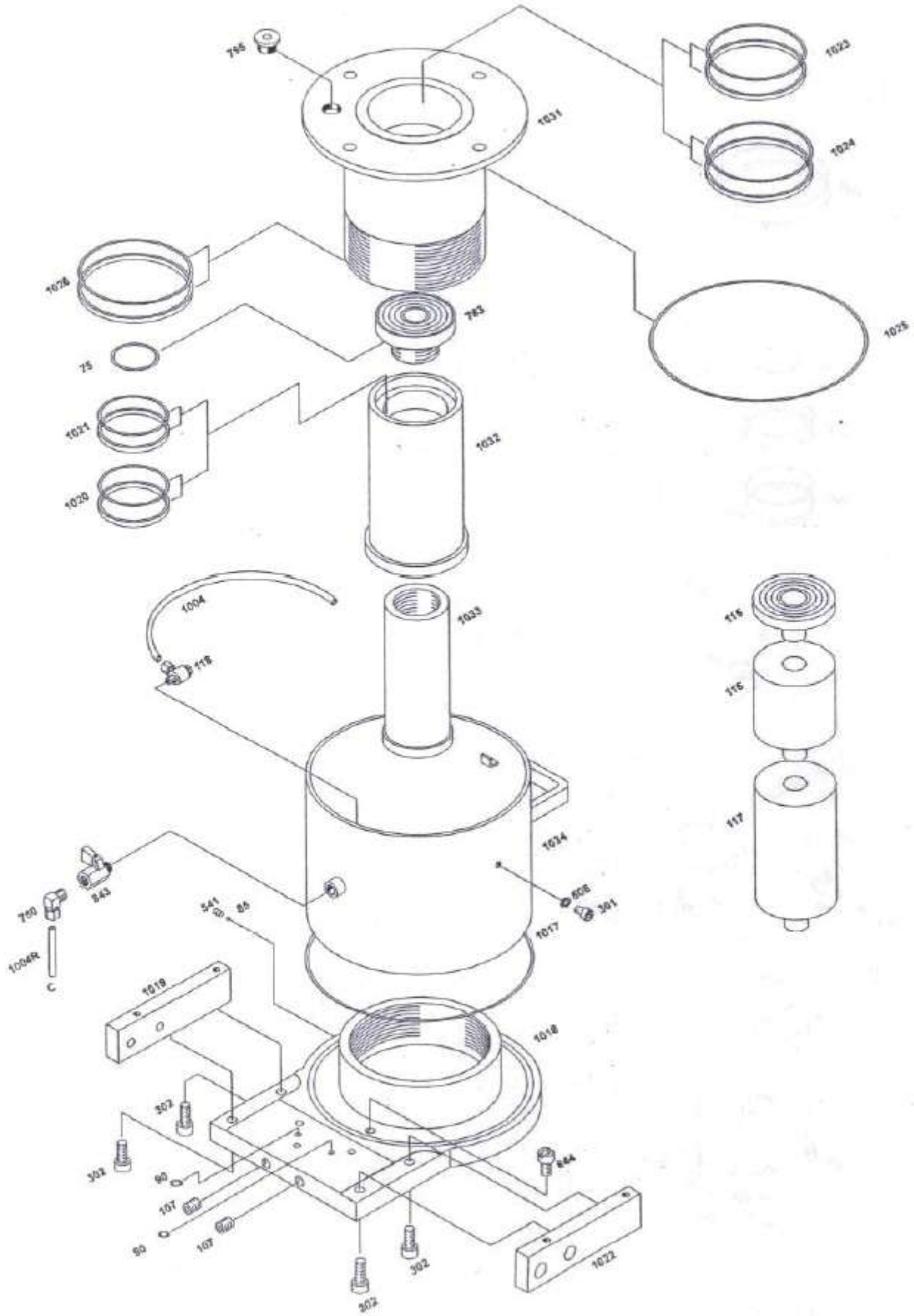

Instruction Manual
Hydropneumatic Trolley 2-Piston "HN-231"

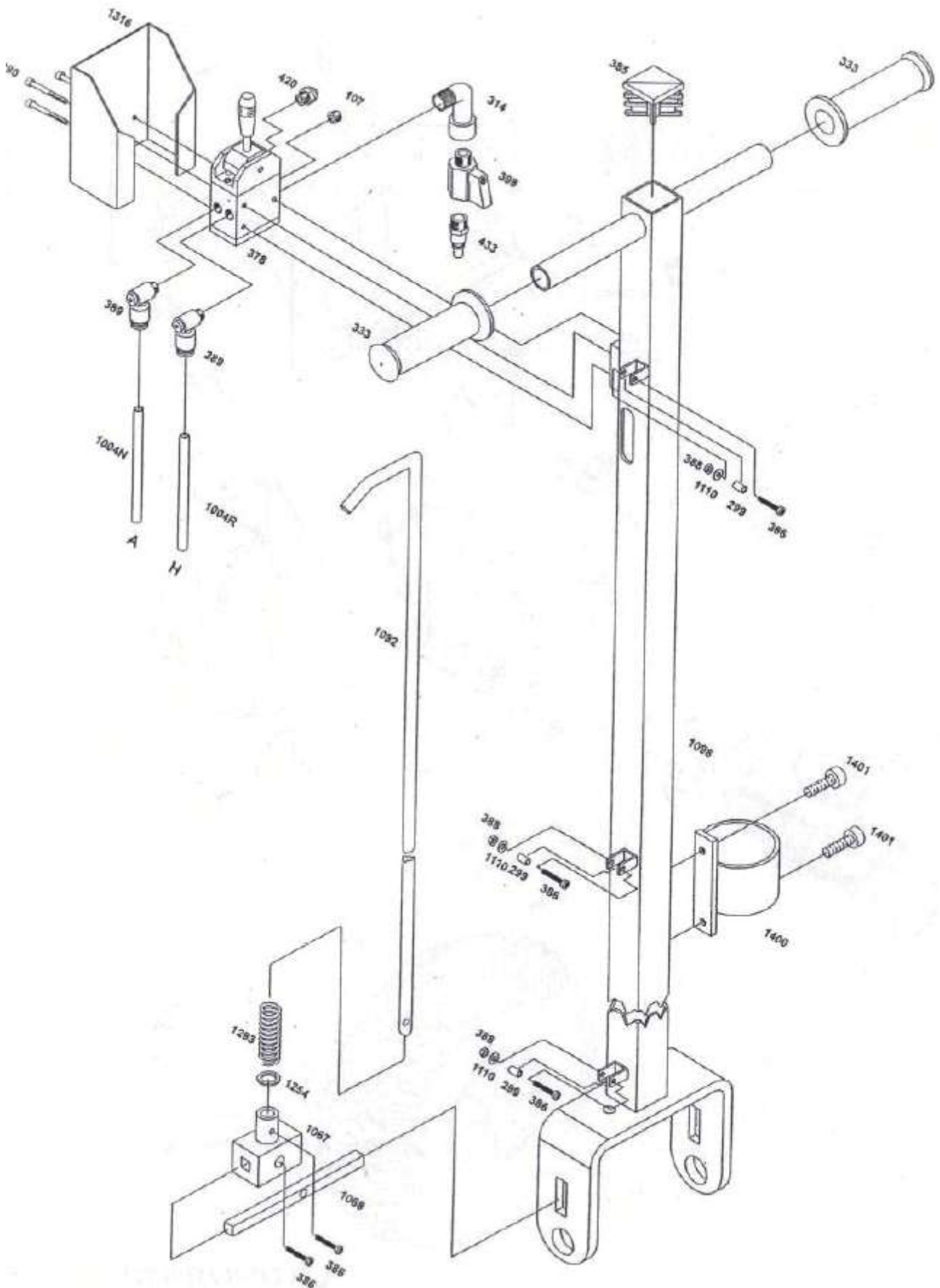

Instruction Manual
Hydropneumatic Trolley 2-Piston "HN-231"

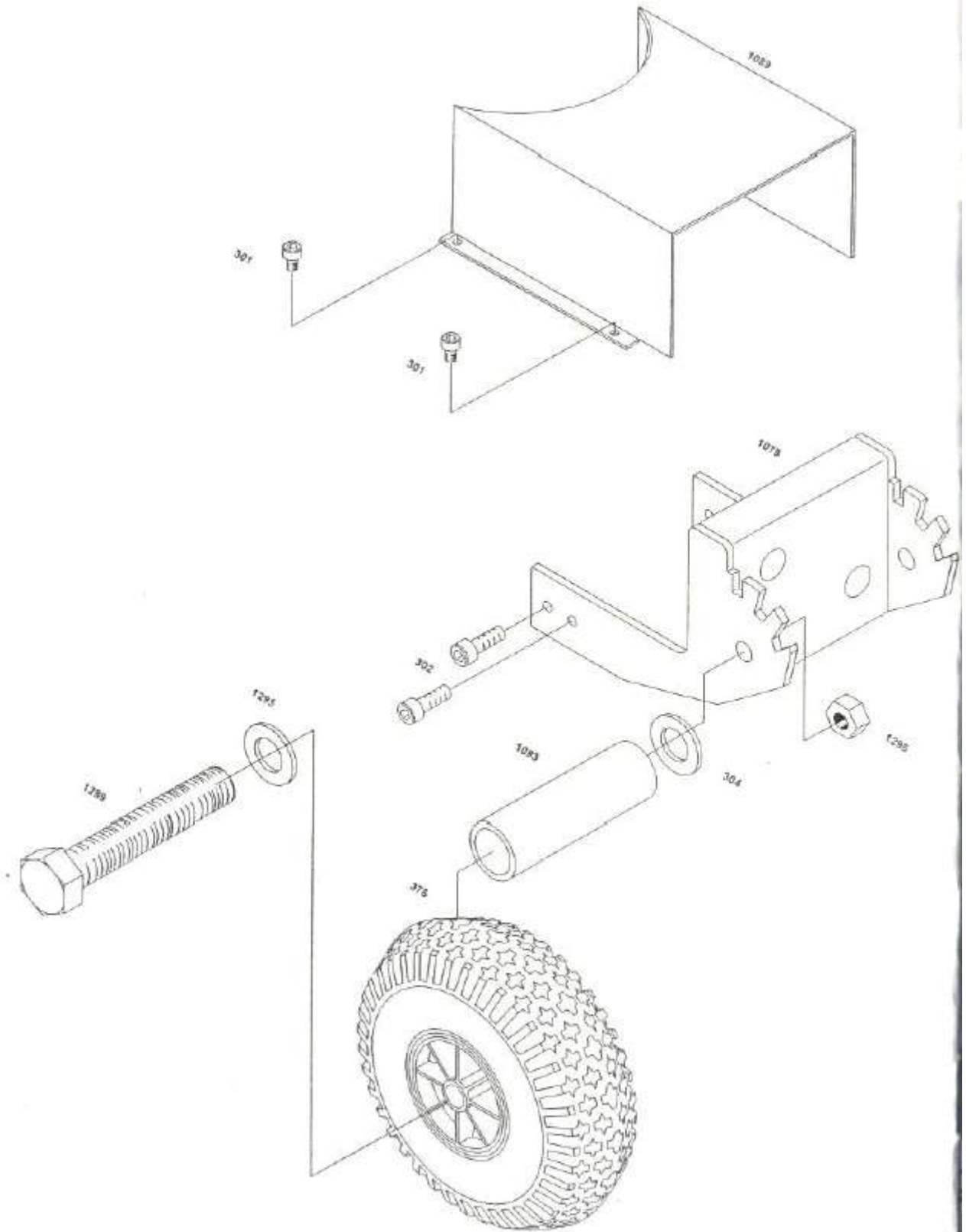

Instruction Manual
Hydropneumatic Trolley 2-Piston "HN-231"

