

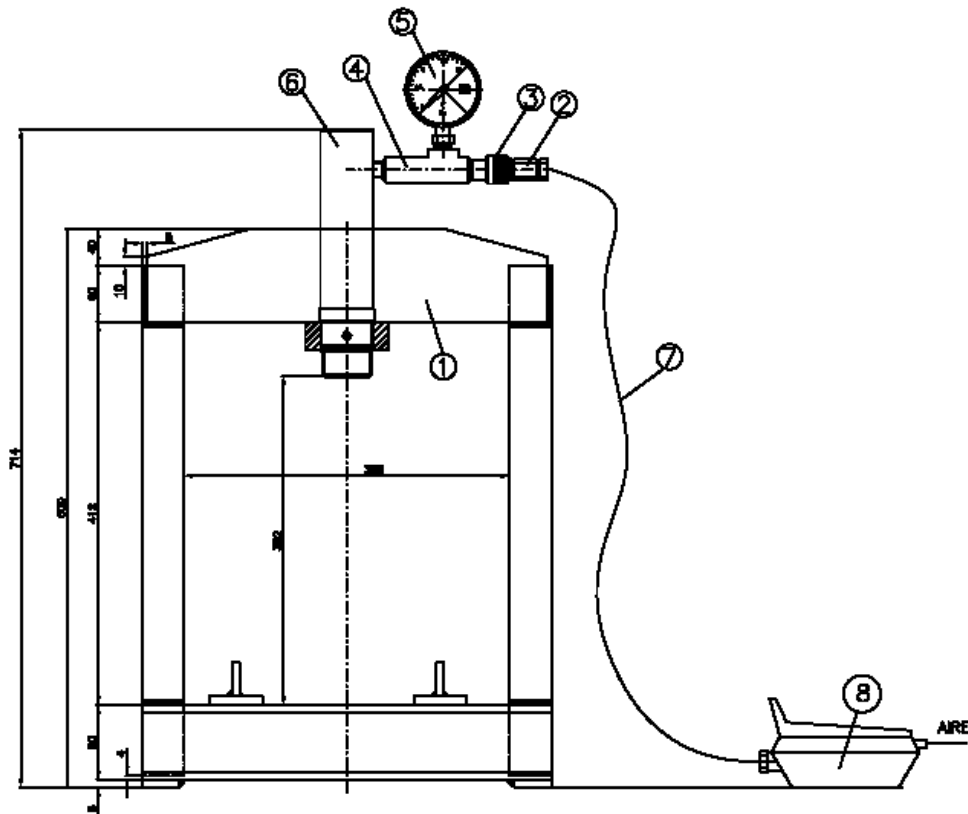

HYDRAULICS

BENCH PRESS 10 Tn 20 Tn AIR PUMP

“ECZ01113” “ECZ02013”



Abdex Hydraulics - Victoria
27 Metcalf Street,
Dandenong South, VIC. 3175
Tel: (03) 9796 3744
Email: sales@abdexhydraulics.com.au

Abdex Hydraulics - Perth
260 Allen Road,
Forrestdale, WA. 6112
Tel: (08) 9418 4988
Email: sales@abdexhydraulics.com.au

Abdex Hydraulics - Queensland
8/315 Archerfield Road
Richlands, QLD. 4077.
Tel: (03) 9796 3744
Email: sales@abdexhydraulics.com.au

INDEX

1. BEFORE USING THE EQUIPMENT	2
2. TECHNICAL FEATURES	3
3. ESSENTIAL SAFETY REQUIREMENTS	3-4
3.1 GENERAL CONDITIONS	
3.2 COMMANDS	
3.3 SAFETY PREVENTION ACTIONS	
3.4 SECURITY IN MAINTENANCE	
3.5 INDICATIONS	
4. TRANSPORT AND ERECTION	4
5. MAINTENANCE	4-5
6. PROBLEMS	5
7. WARRANTY	5
8. DECLARATION OF CONFORMITY	6

ANNEX

- GENERAL DRAWINGS

1. BEFORE USING THE EQUIPMENT.

Upon removing the protective packaging from the crane, carefully inspect it. Check for:

- 1- Oil leaks.
- 2- Signs of corrosion.
- 3- Damage to the hydraulic cylinder and hydraulic line.
- 4- Cracks or dents on the frame and the hydraulic cylinder's attachments to the frame.
- 5- Loose or damaged screws or joints.
- 6- Damaged or incorrectly assembled accessories.

If you find any damage or fault with the product, clearly label it and place it in a location where it will not be available for use until an authorized service dealer has repaired the fault.



Never use hydraulic equipment that is damaged or suspected to be in poor condition.

Familiarize yourself and your co-workers with the equipment. Before you begin using the jack, carefully read and observe all instructions and recommendations enclosed in the packaging.

Your negligence in this matter may cause personal injury or material damage.



Do not loose the instruction manual.

Before using the equipment for the first time, purge any air from the hydraulic circuit by opening the pump's relief valve, placing the pump with its head down, and pumping several times.

Do not operate hydraulic equipment near open flame, explosives, sources of intense heat or any other hazard, which could cause a fire or the damage equipment. The hydraulic equipment should not be exposed to temperatures greater than 60°C when in use or when stored.



If purchasing just a cylinder or pump for use in a press, ensure that you are using the proper combination of pump, cylinder and press frame before assembling the unit. We recommend you seek professional advise on the matter.

When choosing a place for the press, ensure that it will be located over firm, level ground such that the entire base of the press contacts the ground. If any doubt exists as to whether the ground will be able to support the press and the additional weight it will see when in use, distribute the weight over a larger area by placing rigid steel beams or planks under the base of the press.

Store the press with the cylinder's piston fully retracted.

We recommend you wrap the cylinder in a protective plastic or place it in a location free of dirt, dust, steel shavings and other foreign matter, which can enter into the cylinder and damage its components.



Do not store or leave the press where it can be accessed by the children.

2. TECHNICAL FEATURES.

CYLINDER

MODEL	KC01113	KC02013
• Max. Pushing Capacity (Tn.)	10 Tn	20 Tn
• Working max. pressure (Kg/cm ²)	700 Kg/cm ²	700 Kg/cm ²
• Stroke (mm.)	130 mm.	130 mm.
• Oil capacity (cc)	214,7 cc	431.37 cc
• Area (cm ²)	15,9 cm ²	33,18 cm ²
• Free advance speed (mm/sg)	1.7 mm/sg	0.9 mm/sg
• Max. Pressure advance speed	1.7 mm/sg	0.9 mm/sg

AIR PUMP

MODEL	Z12107	Z12107
• Tank capacity (cc)	2100 cc	2100 cc
• Working pressure (Kg/cm ²)	700 Kg/cm ²	700 Kg/cm ²
• Weight (Kg)	4,6 Kg.	4,6 Kg.

WELDED-MECHANIZED FRAME

MODEL	ECZ01113	ECZ02013
• Working height (mm.)	352 mm.	330 mm.
• Working Width (mm.)	350 mm.	500 mm.
• Total weight of the machine (Kg.)	42 Kg.	90 Kg.

3. ESSENTIAL SAFETY REQUIREMENTS.

3.1 GENERAL CONDITIONS.

DANGEROUS AREA



Due to the *FUNCTIONAL REASONS* it is considered to be the space between the columns, the bed and the hydraulic cylinder piston.
Due to the *MATERIAL PRESSED* it is supposed to be surrounding area to the machine in case of metal parts being ejected during pressing.

The speed of the hydraulic cylinder during its extension is less than 30 mm/second. Therefore then machine should be considered by the application of ANNEX V of the Declaration of CE Conformity.

Operators standing in the dangerous area around the machine should protect their feet, faces and hands from metal pieces being ejected during pressing.



Feet protection



Face protection



Hands protection

Used materials and components are not for the health and safety of operators. The hand pump contains LARZEP hydraulic oil ISO: HV46.



HIDRAULIC OIL IS TOXIC IF IT ENTERS THE BLOODS STREAM. NEVER PLACE A FINGER OVER ANY ORIFICE OR LEAK, WHICH COULD BE PRESSURIZED, SUCH AS THE HYDRAULIC LINE, AS THIS COULD CAUSE OIL TO BE INJECTED INTO BLOOD STREAM.

3.2 COMANDS

The cylinder advances when we drove the pedal of the air pump.

The pump's pedal has three positions: advance ("pump"), retroacting (Release) and it maintains the pressure loosen the pedal.

In order to start the equipments it is necessary to connect the pump to the compressed air connection at 6 Bar pressure.

In order to stop the cylinders advance, release the pedal or disconnect the compressed air feeding. For a new beginning it will be necessary to unblock the device and push the pedal in "pump" position.

3.3 SAFETY PREVENTIVE ACTIONS AGAINST MECHANICAL RISKS

The construction of machine has been calculated to bear without any breaking under conditions of foreseen utilization and for the whole life of the machine. The hydraulic components have been designed and calculated in compliance with the ANSI B30.1, and have been proved to 875Kg./cm² of pressing.

The frame of the machine does not cause to be dangerous in that sense.

The hydraulic pump is equipped with an internal security valve in the tank, out of operator's control and rated at 700 Kg./ cm². The hydraulic cylinder is also furnisher with a pressure relief valve, rated at 700 Kg./ cm², which prevents the retraction chamber of the cylinder from overpressures in case of obstruction of the return way.

3.4 MAINTENANCE

All the maintenance operations must be performed while the machine is stopped, thus avoiding this way any potentially dangerous situation. A poor maintenance program of the press does not increase the risk, but obviously will revert in a lower performance. The hydraulic pump is mounted out of the frame and access is very easy. To disassemble the pump unscrews the bolts in the tap cover. In order to disassemble the cylinder it is required first to disassemble the hose and the cylinder from the frame.

ISOLATION OF THE POWER SUPPLY

Release the rapid coupling from the pump.

3.5 INDICATIONS

INFORMATION DEVICES

- In the pump: Oil level, oil filling tap, pressure regulation valve and additional gauge connection.
- In the cylinder: A gauge in order to know the operating pressure anytime.

The press, the cylinder and the pump have their corresponding serial numbers marked on them. In addition to it, you can find a sticker label showing the commercial reference, capacity, working pressure, name and address of the manufacturer.

4. TRANSPORT AND ERECTION.

The machine is delivered properly packed in a wooden ballet. For it's handling, it is recommended to use a forklift truck or a crane. In the last case, it is necessary to make the slings trespass the arc of the frame. When doing this operation, you should be cautious and prevent the flexible hoses and couplings from any damage.



The machine is stable enough to operate without fixing, but if is placed in an area commonly operated by mobile machinery (cranes, lifting equipment...) it is strongly recommended to fix it to the desired place by drilling the supporting plates.

HYDRAULIC CONNECTION

Unscrew the rapid coupler site in the cylinder, and connect the hose, screwing the rapid coupler to the limit with the hand.

SUBSTITUTION OF THE TRANSPORT PLUG

Replace the plug of transport located in the cover of the deposit, by the pressurized plug given with the press. (Plastic Stock market in the handle of the distributing valve).

INSTALLING THE GAUGE

- 1- Replace the threaded tap in the top of the cylinder by the gauge, which is supplied separately.
- 2- Tighten the gauge cone to the gauge adaptor seat by using a flan wrench size 22.
- 3- Hold the gauge screen by hand during threading process and after reaching a comfortable reading position set the gauge screen free so that it turns the last quarter solidarily with the thread.
- 4- The hydraulic system also includes a gauge adaptor with 3/8 " BSP thread.

PNEUMATIC CONNECTION

- 1- Connect the pedal to the compressed air connection.
- 2- Ensure that the pedal is not pushed.

CHECKING THE RIGHT OPERATION OF ALL DEVICES AND MECHANISM

- 1°- Select the working maximum pressure.
- 2°- Put the feet in the pedal.
- 3°- Push the "pump" position.
- 4°- Check the cylinder advances.
- 5°- Check that the cylinder piston goes back pushed by the internal spring. In both cases, to maintain the movement is necessary to push the pedal.
- 6°- Without put anything in the press, repeat the push movement, pushing until reaching the cylinder full stroke (130 mm). In that moment the pressure will start to be increased and we can observe it now in the gauge. This pressure will go on increasing until reaching the installation maximum pressure, previously chosen. In this stage, the cylinder maintains the reached pressure, (the gauge maintains the reading). Check there are no leaks in the installation (gauge intake, couple, etc.)
- 7°- To retract the cylinder and eliminate the installation pressure push the pedal "release". The piston retracts pushed by the internal spring. The return may be slower at the end of the backstroke.
- 8°- Put the material to be treated in the press.

5. MAINTENANCE.

The hydraulic circuit of the press is closed, so in normal conditions no oil leakage should be coming up.

In case of oil leakage, after the proper repairing work, you should fill up the tank with hydraulic oil by LARZEP (Ref. AZ8901); the pump is equipped with an oil level indicator to control the need quantity of oil.

As far as a non-continuous use of the press is concerned (1 hour per day), oil replacement should be done once a year.



To empty the tank, you should remove the cover and take the oil out to another container. Please, bear in mind the existing rules for waste processing when handling the used oil. Keep greasy and lubricated the pin bearings, the piston and in general all the parts that might be in friction

TYPE OF INSPECTION

FREQUENT: a visual inspection carried out before and after each operation.

PERIODIC: a thorough examination of the equipment, both externally and internally. The equipment is labelled with the inspection date and the data is logged in a register.

PARTS TO INSPECT

In a **FREQUENT INSPECTION**, check for:

- Piston wear
- Signs of corrosion
- Wear or damage to the cylinder or pump
- Cracks, dents or any other damage to the frame, cylinder attachments, work table and its supports
- Oil leaks
- Loose or damage screws or joints
- Damaged or incorrectly assembled accessories

In a **PERIODIC INSPECTION**, check for the same problems as in a frequent inspection but in addition, the hydraulic equipment should be disassembled and cleaned by an authorized service dealer so that it may be examined internally.

Periodically clean and lubricate the press's moving parts, such as the piston, winch, pumping mechanism, etc. This is especially important when working in salty or humid environments.

Hydraulics equipment, which is subject to the very severe environmental conditions mentioned, previously should be cleaned and relubricated after each use.

To clean the hydraulic equipment, begin by removing the pump's oil reservoir plug and draining all the oil. Fill reservoir with kerosene and thoroughly circulate it through the hydraulic equipment. After completely purging the kerosene out of the hydraulic circuit, align the pump vertically with the head down and fill the reservoir with the new hydraulic oil until the oil level rises to the orifice

USE ONLY LARZEP HYDRAULIC OIL

Other grades of oils or types of hydraulic fluid (such as brake fluid) may affect the performance of the equipment or cause the deterioration of the seals.



DO NO ATTEMPT TO FILL THE PUMP WITH OIL WHILE IT IS CONNECTED TO A CYLINDER WHICH IS SUSTAINING A LOAD BECAUSE IT MAY OVERPRESSURIZE THE RESERVOIR WHEN THE PISTON RETRACS AND CAUSE DAMAGE OR INJURY

Always use the original LARZEP parts to prolong the service life of your hydraulic equipment. **LARZEP S.A.** or your authorized dealer can supply you with original parts for simple maintenance work.

6. PROBLEMS, CAUSES AND SOLUTIONS.

PROBLEMS	POSSIBLE FAILURES	SOLUTION
1. The piston does not advance.	- Prime less pump.	1. Feed the pump keeping it started some minutes.
	- Dirty accumulated in the filter.	2. Extract and clean it.
	-No oil in the reservoir.	3. Check the level.
	- Cylinder pressure retainer damaged.	4. Replace the retainer.
	-Directional valve damaged.	5. Replace the valve.
	- Cylinders body damaged.	6. Repair the body of the cylinder.
	- Pneumatic problem.	7. Check the installation.
2. The cylinder does not reach pressures.	- Pressure relief valve unrated.	8. Rate the valve.
	- Cylinder pressure retainer damaged.	See Solution. 4.
	- Cylinders body damaged.	See Solution. 6.
3. The cylinder does not maintain pressure.	- Cylinder pressure retainer damaged.	See Solution. 4.
	- Directional valve damaged.	See Solution. 5.
4. The cylinder does not retract.	- Damaged return spring.	9. Replace the spring.
	- Directional valve damaged.	See Solution. 5.

The solutions marked in black must be carried out by specialized personnel, for it, go to an authorized distributor that sold you the equipment or to LARZEP, S.A., we have original spare part kits as well as the necessary personnel, do not doubt in contacting to us, we are to yours disposition.

Always use original spare parts LARZEP, you will extend the life utility of the equipment, in opposite case the company will not become person in charge of the possible failures, damages or losses that take place.

7. WARRANTY.

LARZEP, S.A. guarantees its products against all design and manufacturing defects for the durations of two years from the date of purchase. This guarantee does not include the ordinary wear of both metal and non-metal parts, abuse, using the equipment beyond its rated capacity and any wear or damage incurred as a result of using a hydraulic fluid which is not recommended by **LARZEP, S.A.**

Please note that if the equipment is disassembled or serviced by anyone other than an authorized service dealer or by **LARZEP, S.A.**, this guarantee is rendered null and void.

In the event of a warranty claim, return the equipment, to **LARZEP, S.A.** or the authorized dealer which sold you the hydraulic equipment, **LARZEP, S.A.** will repair or replace the faulty equipment, whichever is deemed most appropriate. **LARZEP, S.A.** shall not be held liable for any consequential damages or losses, which may occur as a result of faulty equipment

8. DECLARATION OF CONFORMITY.

DECLARACION DE CONFORMIDAD

LARZEP, S.A.
Dirección: Avda. Urtiaga, 6
48269 Mallabia ESPAÑA

E

Declaramos bajo nuestra exclusiva responsabilidad la conformidad de los productos a los que refiere esta declaración, con las disposiciones de la directiva: 89/392/CEE, 91/368/CEE, 93/44/CEE, 93/68/CEE, 98/37/CEE

DECLARATION OF CONFORMITY

Nous, LARZEP, S.A.
Adresse: Avda. Urtiaga, 6
48269 Mallabia SPAIN

F

Déclarons sous notre seule responsabilité que les produits auxquels se réfère cette déclaration sont conformes aux dispositions des Directives: 89/392/EEC, 91/368/EEC, 93/44/EEC, 93/68/EEC, 98/37/EEC

DECLARAÇÃO DE CONFORMIDADE

Nós, LARZEP, S.A.
Endereço: Avda. Urtiaga, 6
48269 Mallabia SPAIN

P

Declaramos, sob nossa única responsabilidade, que os seguintes produtos, incluídos nesta declaração estão em conformidade com o disposto na Directiva: 89/392/EEC, 91/368/EEC, 93/44/EEC, 93/68/EEC, 98/37/EEC

ÖVERENSSTEMMELSEERKLÄRING

Vi, LARZEP, S.A.
Adresse: Avda. Urtiaga, 6
48269 Mallabia SPAIN

DK

Erklærer på eget ansvar, at følgende produkter som er omfattet af denne erklæringen, er i overensstemmelse med bestemmelserne i Direktiv: 89/392/EEC, 91/368/EEC, 93/44/EEC, 93/68/EEC, 98/37/EEC

ERKLÄRING OM ÖVERENSSTEMMELSE

Vi, LARZEP, S.A.
Adresse: Avda. Urtiaga, 6
48269 Mallabia SPAIN

N

Erklærer på eget ansvar, at følgende produkter som dekkes av denne erklæringen, er i overensstemmelse med bestemmelserne i Direktiv: 89/392/EEC, 91/368/EEC, 93/44/EEC, 93/68/EEC, 98/37/EEC

ÜBEREINSTIMMUNGSKLÄRUNG

Wir, LARZEP, S.A.
Anschrift: Avda. Urtiaga, 6
48269 Mallabia SPAIN

D

Erklären auf eigene Verantwortung, daß folgende Produkte, auf die sich diese Erklärung bezieht, mit den Bedingungen der Direktiven 89/392/EEC, 91/368/EEC, 93/44/EEC, 93/68/EEC, 98/37/EEC übereinstimmen.

Tipo, Type, Typ, Tyypki.

SM / SX / SP / SMX / SMP / SH / DH / D / SL / STX / TE / T / SMA / SHA / SS / DD / ST / KC / CT / C / CY / W / X / WA / XA / WH / WI / Z / YA / YG / YZ / A / AB / AC / AF / BL / B / F / HN / EC / EE / EG / EM / EZ / CC / CN / CK / CD / VA / VB / VC / VZ / CA / CS / DL / DP / DLG / AA / AU

Mallabia, ESPAÑA 2000 / 01 / 01

Lugar y fecha, place and date, lieu et date, plats och datum, paikka ja päivämäärä, udstedelsessted og-dato, ort und datum, plaats en datum, local e data, luogo e data.

DECLARATION OF CONFORMITY

We, LARZEP, S.A.
Address: Avda. Urtiaga, 6
48269 Mallabia SPAIN

GB

Declare under our sole responsibility that the following products to which this declaration relates conform with the provisions of Directives: 89/392/EEC, 91/368/EEC, 93/44/EEC, 93/68/EEC, 98/37/EEC

DICHIARAZIONE DI CONFORMITÀ

Noi, LARZEP, S.A.
Indirizzo: Avda. Urtiaga, 6
48269 Mallabia SPAIN

I

Dichiariamo sotto la nostra esclusiva responsabilità che i prodotti ai quali questa dichiarazione si riferisce sono conformi quanto previsto dalle Direttive: 89/392/EEC, 91/368/EEC, 93/44/EEC, 93/68/EEC, 98/37/EEC

VAATIMUSTEMUKAISUUSVAKUUTUS.

Me, LARZEP, S.A.
Osoite: Avda. Urtiaga, 6
48269 Mallabia SPAIN

FIN

Vakuutamme yksinomaan omalla vastuullamme, että seuraavat tuotteet, joihin tämä vakuutus liittyy, ovat seuraavien Direktiivien vaatimusten mukaisia: 89/392/EEC, 91/368/EEC, 93/44/EEC, 93/68/EEC, 98/37/EEC

VERKLARING VAN OVEREENKOMST.

Wij, LARZEP, S.A.
Adres: Avda. Urtiaga, 6
48269 Mallabia SPAIN

NL

Verklaren geheel onder eigen verantwoordelijkheid dat de volgende producten, waarop deze verklaring heeft in overeenstemming zijn met de bepalingen van Richtlijn: 89/392/EEC, 91/368/EEC, 93/44/EEC, 93/68/EEC, 98/37/EEC

FÖRSÄKRAN OM ÖVERESSTÄMMELSE

Vi, LARZEP, S.A.
Address: Avda. Urtiaga, 6
48269 Mallabia SPAIN

S

Försäkrar under eget ansvar att följande produkter som omfattas av denna försäkran är i överensstämmelse med villkoren i Direktiv: 89/392/EEC, 91/368/EEC, 93/44/EEC, 93/68/EEC, 98/37/EEC



LARZEP, S.A.

Nombre y firma, name and signature, nom et signature, namn och underskrift, nimi ja nimikirjoitus, navn og underskrift, name und underskrift, naam en handtekening, nome e assinatura, nome e firma.

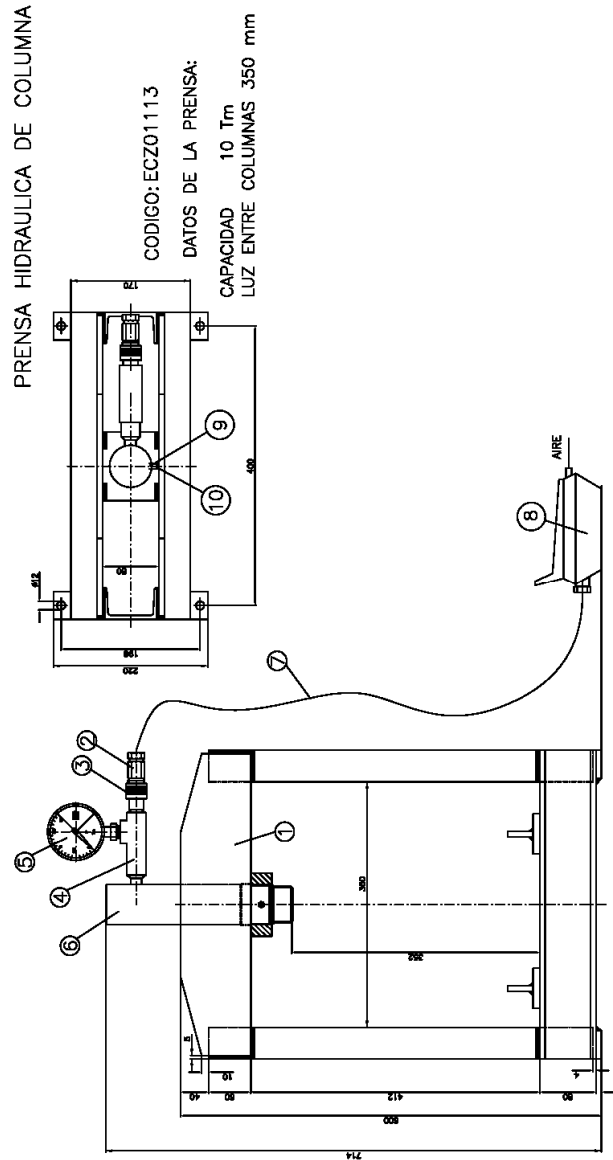

N°	DENOMINACION	CODIGO	N° Piezas
1	ESTRUCTURA	25A0017	1
2	ENCHUFE RAPIDO MACHO	AZ3220	1
3	ENCHUFE RAPIDO HEMBRA	AZ3240	1
4	ADAPTADOR MANOMETRO	AZ1501	1
5	MANOMETRO	AY01008	1
6	CILINDRO	KC01113	1
7	MANGUERA	AP2020	1
8	BOMBA	Z12107	1
9	PROTECTOR ROSCA	15L0018	1
10	ESPARRAGO	14F0010	1
11	TAPON MANOMETRO	15L0014	1

CILINDRO SIMPLE EFECTO RETORNO MUELLE

Ref. Comercial: KC01113

CAPACIDAD 11.12 Tm (109.1 Kn)
 PRESION 700 Kg/Cm
 ALTURA CERRADO 284 mm
 CARRERA 133 mm
 AREA 15.9 Cm²
 VOLUMEN ACEITE 214.7 Cm³

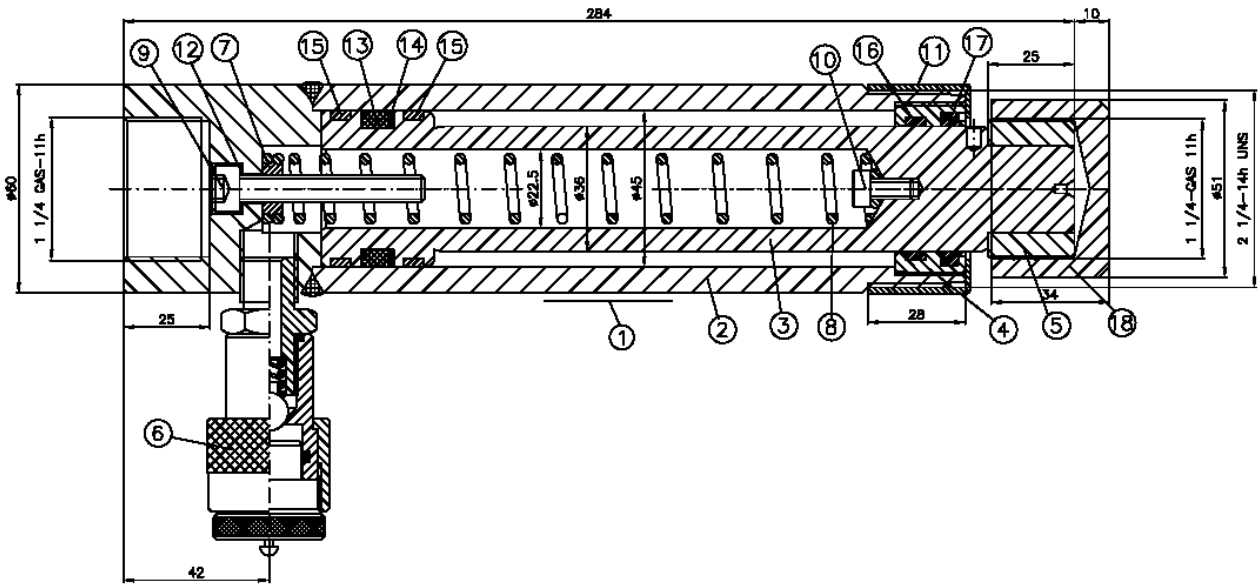

N	DENOMINACION	REFERENCIA JUNTAS	CODIGO	N Piezas
1	ETIQUETA		30A0017	1
2	C.CUERPO		52H0007	1
3	EMBOLO		53H0012	1
4	GUIA		55E0054	1
5	CABEZA		56H0008	1
6	ENCHUFE HEMBRA P.C		AZ3240	1
7	AMARRA MUELLE		24F0071	1
8	MUELLE		13A0139	1
9	TORNILLO ALLEN M8x55 TODO ROSCA		14A0117	1
10	TORNILLO ALLEN M6x10		14A0004	1
11	PROTECTOR ROSCA		12L0002	1
12	ARANDELA COBRE		57B0005	1
* 13	COLLARIN $\phi 45 \times \phi 35 \times 7.3$	4315700	12B0199	1
* 14	SEGMENTO		57A0052	1
* 15	ARO GUIA $\phi 45 \times 40 \times 5.6$	GP6500450-C380	58F0136	2
* 16	ARO GUIA $\phi 36 \times \phi 41 \times 5.6$	GR6500360-C380	58F0123	1
* 17	RASCADOR $\phi 36 \times \phi 44 \times 6$	WD2200360-WUAQ3	12H0063	1
18	CABEZA DENTADA		56H0003	1

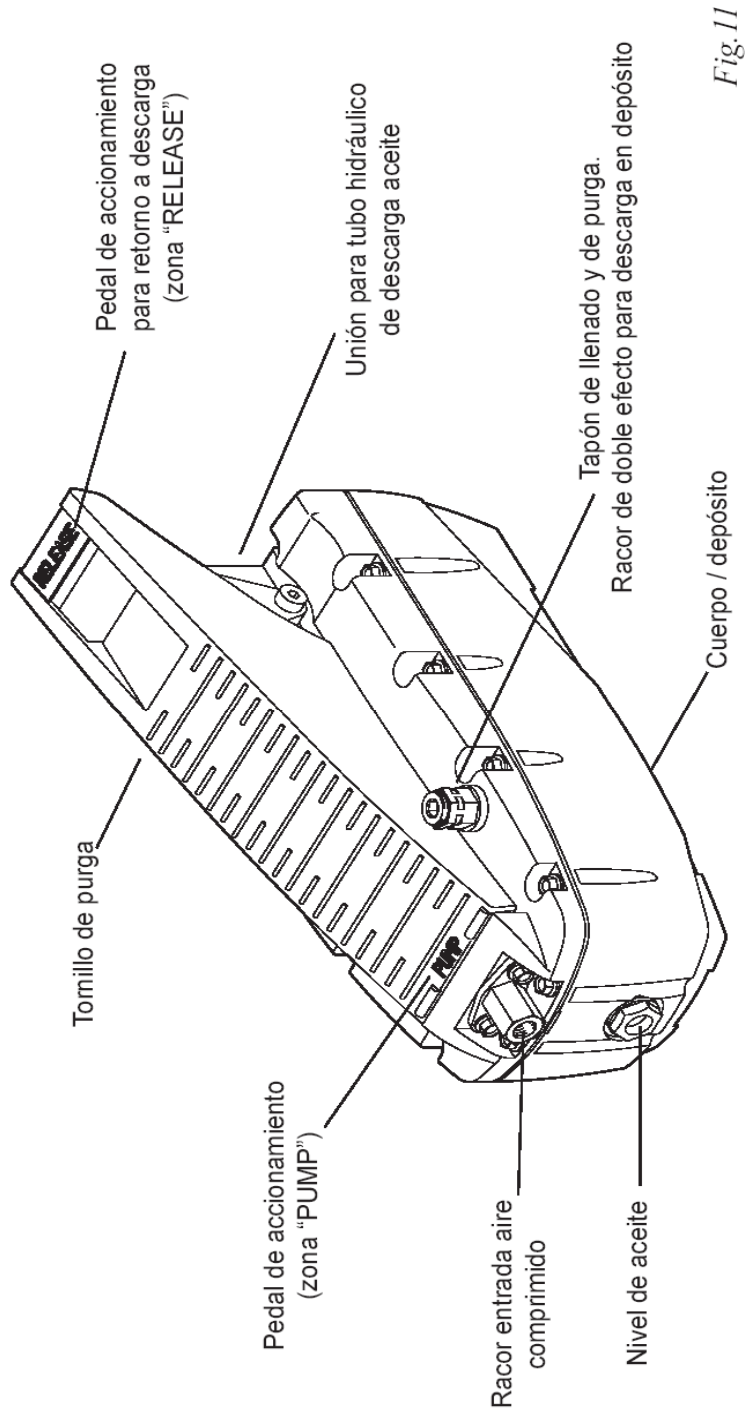

Fig. 11