

DYNAMOMETERS & LOAD CELLS



- ✓ Accuracy $\pm 4\%$ full scale.
- ✓ 5 to 100 Tn models available for dynamometers, and 5 to 150 Tn models for load cells.
- ✓ Includes glycerine filled gauges with maximum load indicating pointer.

CT DYNAMOMETERS

- ✓ Measure loads in compression.
- ✓ Can be used for measuring tension loads in cables, tensile testing and can be used as a weighing device.

C LOAD CONTROL CELLS

- ✓ Portable compression load cells, measure loads in compression.
- ✓ All models have remote mounted gauge with 0,8 metre hose AP2008.



Type **CT - C**

Capacity **5 - 150 Tn**

Max. pressure **700 bar**

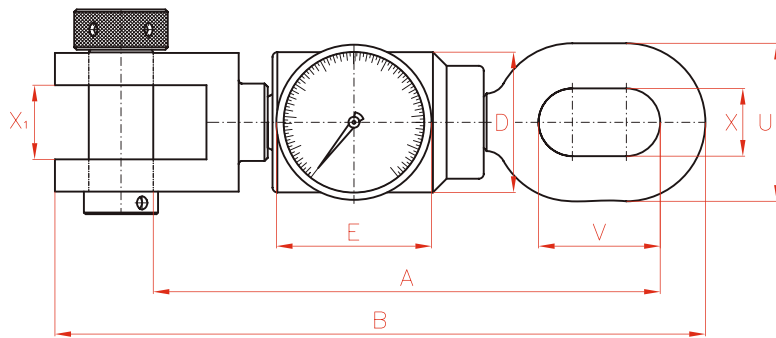

DYNAMOMETERS

Capacity		Model	A	B	D	E	U	V	X	X1	Weight	Gauge	
Tn	kN	LARZEP	mm	mm	mm	mm	mm	mm	mm	mm	kg	Model	Scale (Tn)
5	49	CT00525	328	397	87	100	98	98	42	46	12,5	AX00510	0,05
10	98	CT01025	367	446	102	100	107	108	46	50	18,5	AX01010	0,1
30	303	CT03025	447	563	125	100	108	153	50	70	27,0	AX03010	0,3
50	486	CT05025	643	793	148	100	130	150	50	50	50,0	AX05010	0,5
100	1.026	CT10025	726	851	260	100	296	146	146	146	120,0	AX10010	1

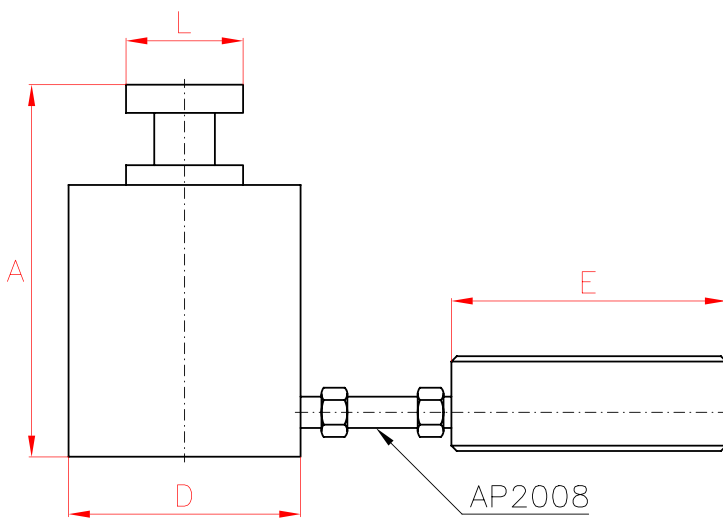

Pressure gauge separated from the load cell with a 0,8 metre hose AP2008.



DDR200015 cylinder. 2.000 Tn capacity cylinder for electronic load cell for pile testing.

LOAD CELLS

Capacity		Model	A	D	E	L	Weight	Gauge	
Tn	kN	LARZEP	mm	mm	mm	mm	kg	Model	Scale (Tn)
5	44	CX00510	39	60	100	25	1,9	AX00510	0,05
10	99	CX01010	54	83	100	38	2,3	AX01010	0,1
30	287	C03010	72	114	100	60	4,8	AX03010	0,3
50	486	C05010	84	140	100	61	7,3	AX05010	0,5
100	953	C10010	103	178	100	88	15,7	AX10010	1
150	1.449	C15010	116	216	100	111	25,7	AX15010	1,5



Larzep designs and manufactures special cylinders for electronic load cells for pile testing. For further information, please contact our Internal Sales department.