

SH03005 SH03015 SH06008 SH06015

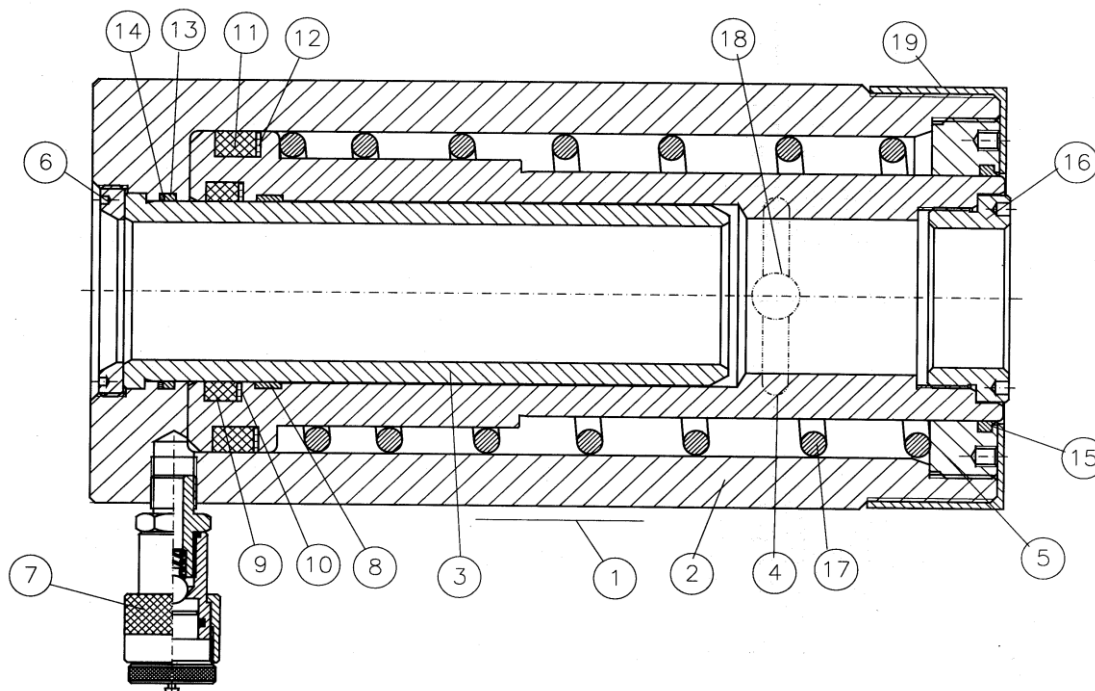

	SH03005	SH03015	SH06008	SH06015
	JR.SH030*	JR.SH030*	JR.SH060*	JR.SH060*
1	30A0023	30A0023	30A0023	30A0023
2	52N0097	52N0092	52N0098	52N0096
3	51C0085	51C0080	51C0086	51C0084
4	53O0058	53O0053	53O0059	53O0057
5	55M0022	55M0022	55M0025	55M0025
6	15O0064	15O0064	15O0056	15O0056
7	AZ3140	AZ3140	AZ3140	AZ3140
*8	58F0131	58F0131	58F0117	58F0117
*9	12B0090	12B0090	12B0202	12B0202
*10	57A0093	57A0093	57A0309	57A0309
*11	12B0085	12B0085	12B0201	12B0201
*12	57A0207	57A0207	57A0308	57A0308
*13	12A0236	12A0236	12A0054	12A0054
*14	57A0302	57A0302	57A0146	57A0146
*15	12H0073	12H0073	12H0066	12H0066
*16	AZ0533	AZ0533	AZ0536	AZ036
17	13D0098	13D0093	13D0099	13D0097
18	33C0004	(2) 33C0004	(2) 24D0019	(2) 24D0019
19	12L0009	12L0009	12L0011	12L0011

Note: JR.SH060A/14 seal kit for SH06008 to serial no 2210257, SH06015 to serial no 2211227

JR.SH060A seal kit for SH06008 serial no 2210258 on and SH06015 serial no 2211228 on..

CAUTION: Trying to disassemble this cylinder without proper material is dangerous because of the strong spring.

LARZEP, S.A.
 Avenida Urutiaga, 6
 48269 MALLABIA, SPAIN
 Tel. +34 943 171200
 Fax. +34 943 174166
 e-mail: sales@larzep.com
www.larzep.com

LARZEP AUSTRALIA PTY. LTD.
 139 Wedgewood Road,
 HALLAM, VIC. 3803 AUSTRALIA
 Tel. +61 (3) 9796 3744
 Fax. +61 (3) 9796 5964
 e-mail: sales@larzep.com.au
www.larzep.com.au