

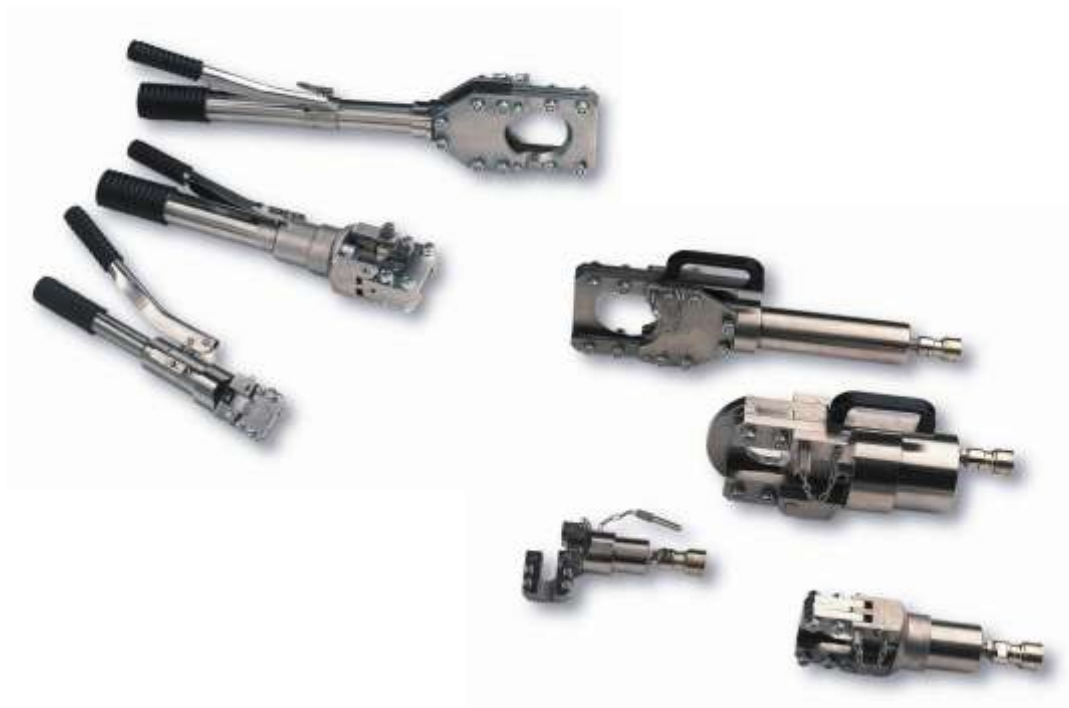

HYDRAULIC TOOLS: CABLE AND BAR CUTTER “CC0075”



LARZEP, S.A.

Avenida Urutiaga, 6
48269 MALLABIA, SPAIN
Tel. +34 943 171200
Fax. +34 943 174166
e-mail: sales@larzep.com
www.larzep.com

LARZEP AUSTRALIA PTY. LTD.

139 Wedgewood Road,
HALLAM, VIC. 3803 AUSTRALIA
Tel. +61 (3) 9796 3744
Fax. +61 (3) 9796 5964
e-mail: sales@larzep.com.au
www.larzep.com.au

LARZEP GB LTD.

3 Commerce Way - Leighton Buzzard
BEDS LU7 4RW UNITED KINGDOM
Tel. +44 1525 377819
Fax. +44 1525 851990
e-mail: sales@larzep.co.uk
www.larzep.co.uk

INDEX

1. BEFORE USING THE EQUIPMENT ----- 2
2. TECHNICAL FEATURES -----2-3
3. ESSENTIAL SAFETY REQUIREMENTS ----- 3
4. START-UP ----- 4
5. MAINTENANCE ----- 4
6. WARRANTY ----- 4
7. DECLARATION OF CONFORMITY----- 5
ANNEX

- GENERAL DRAWING

1. BEFORE USING THE EQUIPMENT.

Remove the tool from its packaging and check for external damage, such as:

- Broken cutting blade.
- Damaged levers.
- Loosed/unscrewed parts.

LARZEP hydraulic tools are designed in accordance with internal quality standards, in compliance with the ISO 9001 regulation.

The tools are designed for the applications described in this manual. Any other use may pose a risk to the equipment and result in hazardous situations for the operator. Always use the tools in well-lit areas.

The manufacturer accepts no responsibility for damage resulting from the improper use of the tool.



Never use hydraulic equipment that is damaged or suspected to be in poor condition.

The operator should be fully aware of the risks inherent in the use of high-pressure hydraulic tools, and should act responsibly in accordance with that described in this manual, ensuring both his/her own safety as well as the safety of others located in the vicinity of the working zone.



Do not loose instruction manual.

The working instructions should be available for consultation by the operator at all times.

In addition to reading and understanding the instructions manual, the operator should be trained in the use of the machine and in the standards and regulations governing operations of this kind, such as those pertaining to accident prevention and environmental protection, for example. All exposed personnel should use appropriate personal protection equipment: boots, helmet, goggles, gloves and protective clothing.



2. TECHNICAL FEATURES.

The tools in the CC cable cutter range are designed to cut cables and bars in accordance with the specifications contained in the table below. Any other use not included in the said specifications may cause irreparable damage to the cutter and render it unable to carry out the task for which it was designed.

When using the cable cutter, the operator should take steps to prevent the cable from fraying. We recommend that, before commencing the cutting operation, the cable be attached to either end of the cutting zone, using tape, wire or another similar means.

The operator should take appropriate steps at all times to prevent exposure to flying particles of cable or bar generated during the cutting process (personal protection equipment, protection screens, etc.).

MODEL		CC0018	CC0040	CC0075
CAPACITY	kN	54 kN	140 kN	70 kN
PRESSURE	bar	550 bar	700 bar	700 bar
WIRE ROPE	STEEL Ø Ext. mm. ALUMMINIUM Ø Ext. mm	18 mm. 18 mm.	40 mm. 40 mm.	40 mm. -
CABLE	TELÉPHONE Ø Ext. mm. LEAD Ø Ext. mm. UNDERGROUND Ø Ext. mm.	- 18 mm 18 mm	- 40 mm. 40 mm.	75 mm. 75 mm. 75 mm.
STEEL ROPE MAX.R = 1800 N/mm ²	Ø Ext. mm. WIRE min.mm.	18 mm. 1 mm.	32 mm. 2 mm.	- -
BAR MAX.R= 400 N/mm ²	STEEL Ø Ext. mm COPPER Ø Ext. mm ALUMMINIUM Ø Ext. mm	12 mm. 15 mm. 15 mm.	20 mm. 30 mm. 30 mm	- - -
BLADE		CRC 18	CRC-35-40	CRC75
DIMENSIONS	A Mm. B Mm. C Mm.	384 mm. 60 mm. 19 mm.	490 mm. 92 mm. 41,5 mm.	650 mm. 126 mm. 77 mm.
WEIGHT		2,8 Kg.	5,6 Kg.	6,8 Kg.

MODELS		CC0118	CC0140	CC0175	CC0190	CC01120	CC0160
CAPACITY	kN	54 kN	135 kN	70 kN	109 kN	135 kN	436 kN
PRESSURE	bar	550 bar	700 bar	700 bar	700 bar	700 bar	700 bar
WIRE ROPE	STEEL Ø Ext. mm. ALUMMINIUM Ø Ext. mm	18 mm. 18 mm.	40 mm. 40 mm.	40 mm. -	35 mm. -	35 mm. -	60 mm. 60 mm.
CABLE	TELÉPHONE Ø Ext. mm. LEAD Ø Ext. mm. UNDERGROUND Ø Ext. mm.	- 18 mm. 18 mm.	- 40 mm. 40 mm.	75 mm. 75 mm. 75 mm.	90 mm. 90 mm. 90 mm.	120 mm. 120 mm. 120 mm.	- - -
STEEL ROPE MAX.R = 1800 N/mm ²	Ø Ext. mm. WIRE min.mm.	18 mm. 1 mm.	32 mm. 2 mm.	- -	- -	- -	60 mm 3 mm.
BAR MAX.R= 400 N/mm ²	STEEL Ø Ext. mm COPPER Ø Ext. mm ALUMMINIUM Ø Ext. mm	12 mm. 15 mm. 15 mm.	20 mm. 30 mm. 30 mm.	- - -	- - -	- - -	25 mm 35 mm 35 mm
BLADE		CRC 18	CRC-35-40	CRC75	CRC0190	CRC01120	CRC0160
DIMENSIONS	A Mm. B Mm. C Mm.	212 mm. 60 mm. 19 mm.	280 mm. 92 mm. 36 mm.	451 mm. 126 mm. 77 mm.	535 mm. 146 mm. 91mm.	630 mm. 178 mm. 122 mm.	403 mm. 105 mm. 62 mm.
WEIGHT		2 Kg.	4,5 Kg.	5,5 Kg.	10 Kg.	11,7 Kg.	12 Kg.

3. ESSENTIAL SAFETY REQUIREMENTS.

- In the event of the improper working of the machine or one of the connected elements, immediately halt all operation, depressurise the system and resolve the problem.
- Before beginning operation, make sure that the dangerous area is unoccupied.



Check that the machine and accessories have not been damaged in any way during transportation to the plant.

- Always use the tools in well-lit areas.
- Regardless of whether the cutting tool has a built-in or separate pump, try to establish the most convenient and stable working method for both the tool and the operator.



Allow for a general use at 80% of the tool's nominal capacity. Do not exceed the tool's nominal capacity.

In the case of tools with separate pumps, we recommend the use of a pressure indicator, in order to enable the operator to monitor at all times the force to which the system is subjected

- When cutting the work piece may project particles and fragments. Therefore, the operator should protect his/her body and (particularly) eyes using appropriate protective equipment.



Goggles Face Protection.

- In the case of tools with a separate pump, the hose enables the operator to move further away from the dangerous area, while in the case of tools with built-in pumps, if possible, a guard should be positioned between the work piece and the operator.
- Do not expose tools to intense heat sources, such as welding equipment, for example.
- Depressurise and disconnect the tools before carrying out any maintenance operations
- The controls of both the tools with built-in pumps and the separate pumps themselves should always be activated manually. Do not use hand tools, levers, etc. to work the controls.
- In the case of tools with separate pumps, make sure all the quick plugs are completely clean before connecting.
- Make sure that the hydraulic hoses are neither twisted nor unduly tensed.
- When working with an electric pump, make sure that the valve is set to its neutral position before connecting the tool.
- When working with cable cutters, fraying may occur during the cutting operation. To avoid this, clamp the cable to either end of the cutting blade with tape, wire or even a bushing.
- Clean the quick plugs thoroughly before connecting.
- In all cases, the operator should be thoroughly trained in the operation of the tool and should act in accordance with the logical safety criteria associated with the use of high-pressure equipment.

4. START UP.

MODELS WITH IN-BUILT PUMP. CC0018, CC0040 AND CC0075	MODELS WITH A SEPARATE PUMP. CC0118, CC0140, CC0162, CC0175, CC0190 AND C01120.
1- Hold the tool by the thick handle and with the tool in an upright position (head facing up).	1- Connect the hose's female quick plug to the tool's male plug. Make sure the connection is secure.
2- Pump the lever to check that the blade moves forward.	2- Read and follow the pump instructions.
3- Make sure the deformation zone is free from obstruction, and then continue pumping until the blade reaches the end of its travel. At this point the lever will become stiffer and harder to move.	3- Remove the pin and open the tool head.
4- Continue pumping until the safety valve is activated. Check for oil leaks.	4- Place the material to be cut in the cavity of the counter-blade and close the head, fixing it in place with the pin. Make sure the pin is properly positioned.
5- Press the unload button and check that the blade returns to its initial position.	5- Pump until the material is cut.
6- Repeat this operation as many times as necessary in order to become familiar with the operation of the tool.	6- Move the blade back activating the pump valve.
7- Remove the pin and open the tool head.	7- Pump until the material is cut.
8- Place the material to be cut in the cavity of the counter-blade and close the head, fixing it in place with the pin. Make sure the pin is properly positioned.	8- When using electric or air-based pumps, the application is automated. In such cases, the operator should be specially trained, in order to avoid the possibility of involuntary actions.
9- Pump until the material is cut.	
10- Once cut, press the unload button to move the blade back. Open the head and remove all traces of waste material before making another cut.	

5. MAINTENANCE.

- After use, the tool should be cleaned and the area where the blade comes into contact with the heads oiled.
- In the event of oil leaks, disassemble the tool and change the seals. The individual blueprint provided for each tool specifies its components and codes.
- During this operation, check the condition of the inside of the cylinder. If scratches or snags are detected, then a more thorough repair procedure will be required. We recommend that this be carried out **by specialist personnel**.
- Check for loose nuts in the head.
- In the event of improper functioning in the models with built-in pumps, we recommend that you send the tool to an authorised technical service for inspection and repair.

CHANGING THE BLADE.

- CC0018, CC0118, CC0075, CC0175, CC0190 and CC01120: pump until the piston and blade move out far enough to provide access to the screw (22). Release the screw and remove the blade. Replace the blade with a new one and attach to the piston by tightening the screw (22) once again.
- CC0040, CC0140 and CC0160: You do not need to pump the piston out, since in these models, the screw (22) can be accessed with the blade in its standby position. Simply remove the screw (22) and replace the blade.

6. WARRANTY.

LARZEP, S.A. guarantees its products against all design and manufacturing defects for the durations of two years from the date of purchase. This guarantee does not include the ordinary wear of both metal and non-metal parts, abuse, using the equipment beyond its rated capacity and any wear or damage incurred as a result of using a hydraulic fluid which is not recommended by **LARZEP, S.A.**

Please note that if the equipment is disassembled or serviced by anyone other than an authorized service dealer or by **LARZEP, S.A.**, this guarantee is rendered null and void.

In the event of a warranty claim, return the equipment, to **LARZEP, S.A.** or the authorized dealer which sold you the hydraulic equipment, **LARZEP, S.A.** will repair or replace the faulty equipment, whichever is deemed most appropriate. **LARZEP, S.A.** shall not be held liable for any consequential damages or losses, which may occur as a result of faulty equipment

7. DECLARATION OF CONFORMITY.**DECLARACION DE CONFORMIDAD**

LARZEP, S.A.
Dirección: Avda. Urtiaga, 6
48269 Mallabia ESPAÑA

Declaramos bajo nuestra exclusiva responsabilidad la conformidad de los productos a los que refiere esta declaración, con las disposiciones de la directiva:
89/392/EEC, 91/368/EEC, 93/44/EEC, 93/68/EEC, 98/37/EEC

E**DECLARATION OF CONFORMITE**

Nous, LARZEP, S.A.
Adresse: Avda. Urtiaga, 6
48269 Mallabia SPAIN

Déclarons sous notre seule responsabilité que les produits auxquels se réfère cette déclaration sont conformes aux dispositions des Directives:
89/392/EEC, 91/368/EEC, 93/44/EEC, 93/68/EEC, 98/37/EEC

F**DECLARAÇÃO DE CONFORMIDADE**

Nós, LARZEP, S.A.
Endereço: Avda. Urtiaga, 6
48269 Mallabia SPAIN

Declaramos, sob nossa única responsabilidade, que os seguintes produtos, incluídos nesta declaração estão em conformidade com o disposto na Directiva:
89/392/EEC, 91/368/EEC, 93/44/EEC, 93/68/EEC, 98/37/EEC

P**ÖVERENSSTEMMELSEERKLÄRING**

Vi, LARZEP, S.A.
Adresse: Avda. Urtiaga, 6
48269 Mallabia SPAIN

Erklærer på eget ansvar, at følgende produkter som er omfattet af denne erklæringen, er i overensstemmelse med bestemmelserne i Direktiv:
89/392/EEC, 91/368/EEC, 93/44/EEC, 93/68/EEC, 98/37/EEC

DK**ERKLÄRINGOM ÖVERENSSTEMMELSE**

Vi, LARZEP, S.A.
Adresse: Avda. Urtiaga, 6
48269 Mallabia SPAIN

Erklærer på eget ansvar, at følgende produkter som dekkes av denne erklæringen, er i overensstemmelse med bestemmelsene i Direktiv:
89/392/EEC, 91/368/EEC, 93/44/EEC, 93/68/EEC, 98/37/EEC

N**ÜBEREINSTIMMUNGSEKTLÄRUNG**

Wir, LARZEP, S.A.
Anschrift: Avda. Urtiaga, 6
48269 Mallabia SPAIN

Erklären auf eigene Verantwortung, daß folgende Produkte, auf die sich diese Erklärung bezieht, mit den Bedingungen der Direktiven 89/392/EEC, 91/368/EEC, 93/44/EEC, 93/68/EEC, 98/37/EEC übereinstimmen.

D

Tipo, Type, Typ, Tyypki.

SM / SH / SP / SMP / SX / SMX / ST / STX / SL / SMA / SHA / SSR / T / TE / TD / D / DH /
DDR / Z / ZR / W / X / YA / YG / YZ / HM / HE / HG / HZ / HS / WI / CK / CC / CN / FU / FV
/ FZ / FA / CY / AA / AU / CT / C / KC

A / AB / AC / BL / B / AF / F / HN / DLG / DL / DP / VA / VB / VC / VZ / EC / EE / EG / EM /
EZ / CA / CS

Mallabia, ESPAÑA 2005 / 04 / 27

Lugar y fecha, place and date, lieu et date, plats och datum, paikka ja päivämäärä, udstedelsessted og dato, ort und datum, plaats en datum, local e data, luogo e data.

DECLARATION OF CONFORMITY

We, LARZEP, S.A.
Address: Avda. Urtiaga, 6
48269 Mallabia SPAIN

Declare under our sole responsibility that the following products to which this declaration relates conform with the provisions of Directives:
89/392/EEC, 91/368/EEC, 93/44/EEC, 93/68/EEC, 98/37/EEC

GB**DICHIARAZIONE DI CONFORMITÀ**

Noi, LARZEP, S.A.
Indirizzo: Avda. Urtiaga, 6
48269 Mallabia SPAIN

Dichiariamo sotto la nostra esclusiva responsabilità che i prodotti ai quali questa dichiarazione si riferisce sono conformi quanto previsto dalle Direttive:
89/392/EEC, 91/368/EEC, 93/44/EEC, 93/68/EEC, 98/37/EEC

I**VAATIMUSTEMUKAISUUSVAKUUTUS.**

Me, LARZEP, S.A.
Osoite: Avda. Urtiaga, 6
48269 Mallabia SPAIN

Vakuutamme yksinomaan omalla vastuullamme, että seuraavat tuotteet, joihin tämä vakuutus liittyy, ovat seuraavien Direktiivien vaatimusten mukaisia:
89/392/EEC, 91/368/EEC, 93/44/EEC, 93/68/EEC, 98/37/EEC

FIN**VERKLARINGVAN OVEREENKOMST.**

Wij, LARZEP, S.A.
Adres: Avda. Urtiaga, 6
48269 Mallabia SPAIN

Verklaren geheel onder eigen verantwoordelijkheid dat de volgende producten, waarop deze verklaring heeft in overeenstemming zijn met de bepalingen van Richtlijn:
89/392/EEC, 91/368/EEC, 93/44/EEC, 93/68/EEC, 98/37/EEC

NL**FÖRSÄKRAN OM ÖVERESSTÄMMELSE**

Vi, LARZEP, S.A.
Address: Avda. Urtiaga, 6
48269 Mallabia SPAIN

Försäkrar under eget ansvar att följande produkter som omfattas av denna försäkran är i överensstämmelse med villkoren i Direktiv:
89/392/EEC, 91/368/EEC, 93/44/EEC, 93/68/EEC, 98/37/EEC

S**LARZEP, S.A.**

Nombre y firma, name and signature, nom et signature, namn och underskrift, nimi ja nimikirjoitus, navn og underskrift, name und underskrift, naam en handtekening, nome e assinatura, nome e firma.

MODEL	CAPACITY	LENGTH	WEIGHT	WIRE ROPE		CABLE			STEEL ROPE		BAR
				ALUMINIUM WITH COPPER	ALUMINIUM WITH STEEL	TELEPHONE	LEAD SHELDED UNDERGROUND	MAX. STRENGTH	STEEL	COPPER ALLOY	
CC0075	70 kN	650 mm.	6,8 Kg.	ØExt. 40 mm.	-----	ØExt. 75 mm.	ØExt. 75 mm.	ØExt. 75 mm.	1800 N/mm ²	-----	-----

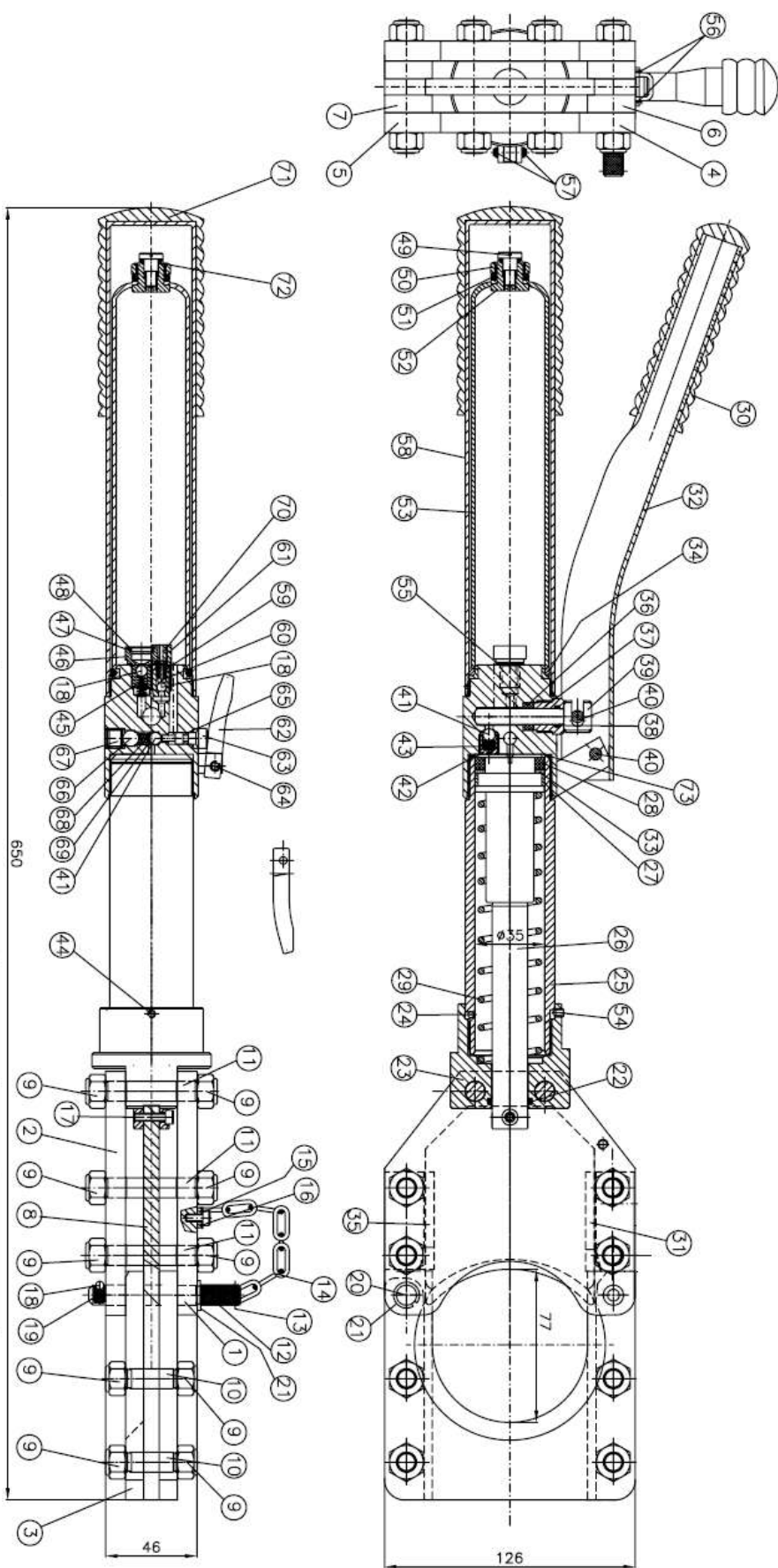

V4 3º Direc. Técnico		MODIFICACIONES		FECHA	
Auto:	DESIGNACION:	VERSION			
PEDRO GOMEZ	CORTADORA				
Ref. Modelo Prima	Fecha	24-3-03			
Dimensiones en Bruto	Dureza	Resistencia	Kg/mm ²		
Peso en Bruto	Kg.	Escala	1:1		
Toerancias para las dimensiones en indicacion en el dibujo		RODADONES ADMISIBILES			
ASLERBDD. H12 - E483 018 - REBILAS. LINDITIONUMALES ± 0,25		M19 < 10µ		M27 < 1,6µ	
		M36 < 0,4µ		M48 < 0,09µ	
		Sustituye a			
		Sustituido por			
		CODIGO		CC0075	
		LARZEP			

N	DESCRIPTION	REFERENCE GASKET	CODE	N PARTS
1	UPPER PLATE BASE		24K0071	1
2	LOWER PLATE BASE		24K0070	1
3	COUNTERBLADE		59B0002	1
4	RIGHT GUIDE BASE		24F0116	1
5	LEFT GUIDE BASE		24F0117	1
6	RIGHT INTERMEDIATE GUIDE BASE		24F0118	1
7	LEFT INTERMEDIATE GUIDE BASE		24F0119	1
8	MOBILE BLADE		CRC75	1
9	SELFLOCKING NUT M10 DIN-985		14B0023	20
10	SADDLE SHAFT		15I0210	4
11	SHAFT		15I0207	6
12	PIN		15I0209	1
13	ELASTIC PIN DIN 1481 ϕ 2x10		14E0026	1
14	11 LINK CHAIN ϕ 2 A=8 L=18		24I0019	1
15	ALLEN SCREW M4x6 DIN 912 8.8		14A0150	1
16	STANDARD WASHER FOR M4		14C0017	1
17	ALLEN SCREW M4x15 DIN 912 12.9		14A0151	1
18	BALL ϕ 4		31A0002	3
19	SPRING		13D0111	1
20	SADDLE PIN		15I0208	1
21	ELASTIC RING FOR ϕ 10 DIN 471		14D0017	3
22	O-RING ϕ 17.2x2.62		12A0015	1
23	SADDLE		56Q0008	1
24	BALL ϕ 3		31A0004	1
25	PUMP TUBE		51A0172	1
26	PISTON		53S0009	1
27	COPPER COLLAR		58A0293	1
28	COLLAR ϕ 25x ϕ 35x5.5	TTU 25-35	12B0275	1
29	SPRING		13D0120	1
30	HANDLE		24C0032	1
31	LEFT BLADE GUIDE		55U0003	1
32	LEVER		24A0037	1
33	SEGMENT		57A0367	1
34	O-RING ϕ 29.74x3.53		12A0004	1
35	RIGHT BLADE GUIDE		55U0004	1
36	COLLAR ϕ 8x ϕ 14x7	TTU 8-14	12B0254	1

N	DESCRIPTION	REFERENCE GASKET	CODE	N PARTS
37	INJECTOR GUIDE NUT		14B0038	1
38	O-RING ϕ 8.73x1.78		12A0266	1
39	PISTON		54A0023	1
40	PIN		15I0201	2
41	BALL ϕ 5.5		31A0007	2
42	RETENTION VALVE SCREW		15O0071	1
43	RETENTION SPRING		13D0113	1
44	ALLEN STUD M4x5		14F0033	2
45	INDRAFT SPRING		13D0112	1
46	INDRAFT VALVE SCREW		15O0072	1
47	BRASS NETTING FILTER		06D0001	0.001
48	NETTING HOLDER COLLAR		15B0064	1
49	OBTURATOR SCREW		15O0074	1
50	NUT		14B0039	1
51	TANK WASHER		57E0012	1
52	TANK SCREW		15O0073	1
53	TANK RUBBER		12M0003	1
54	ALLEN STUD M4x5		14F0033	1
55	COPPER WASHER ϕ 14x ϕ 10x1.5		57B0031	1
56	SECURITY RING FOR ϕ 6 DIN 6799		14D0024	4
57	SECURITY RING FOR ϕ 3.2 DIN 6799		14D0048	2
58	TANK COVER TUBE		51A0164	1
59	RESTRICTOR VALVE SPRING		13D0109	1
60	BALL BUTTON		15N0021	1
61	SECURITY VALVE BODY		52Y0037	1
62	BUTTON LEVER		24A0036	1
63	UNLOADING BUTTON		15N0025	1
64	BUTTON PIN		15I0200	1
65	O-RING ϕ 2.9x1.78		12A0075	1
66	BALL ϕ 7.5		31A0021	1
67	ALLEN STUD M10x10		14F0014	1
68	SPRING		13D0110	1
69	STANDARD WASHER FOR M3		14C0018	1
70	STUD M6x6		14F0034	1
71	HANDLE		24C0035	1
72	O-RING ϕ 6.75x1.78		12A0272	1
73	O-RING ϕ 37.82x1.78		12A0279	1
74	BODY		52U0013	1